

Operator Interface Products

Contents

<i>Description</i>	<i>Page</i>
ELC Graphics Panels	
Graphics Panels	48-2
Software and Accessories	48-4
Dimensions	48-6
HMI Operator Interface	
Operator Interface	48-8
Software and Accessories	48-10
Dimensions	48-14
PanelMate® Operator Interface	
Product Family Overview	48-17
ePro PS	48-18
Stand-Alone Touchscreen Displays	48-24
Canvas™ Editing Software	48-25
Power Pro LT 1100, 1700, 3000 and 5000	48-26
PC Pro Runtime Hardware Key	48-30
Power Pro Software	48-31
Connectivity: Utilities, Interfaces and Cables	48-32
Accessories	48-35
Legacy Products Spare Parts	48-37



HMI Operator Interface

ELC Graphics Panels

Product Description

ELC Graphics Panels are simple to program and easily connect to ELC products. ELC graphics panels make modifying an application quick and easy and also connect to Cutler-Hammer® MVX drives, IQ Modbus® meters and many other devices. With over 30 objects that can be placed anywhere on the display, these tough panels also communicate to other major controllers. These graphics panels have two serial ports that can be used simultaneously to communicate. Transfer applications to or from these graphics panels using the handy transfer module. Ten programmable functions keys provide easy-to-change pages, input numeric values, enter alpha-numeric passwords, set, reset and more. Create alarms, password protect, import bitmaps and use many different fonts.

Protocols Supported

- Eaton D50/D32LT, D320
- Eaton ELC
- Eaton MVX ASCII
- Eaton MVX RTU
- Modbus ASCII
- Modbus RTU
- AB DF1
- Mitsubishi® FX Series
- Mitsubishi® FX2N Series
- Koyo K-Sequence
- LG® 200S
- OMRON C-Series
- Siemens® 57-200 Series
- ASCII Slave Mode
- And more...



ELC-GP02



ELC-GP04

Features

Table 48-1. ELC Graphics Panel Features

Item	ELC-GP02	ELC-GP04
Display Screen		
Screen	STN-LCD	
Color	Monochromatic	
Back-light	The back-light automatic turn off time is 1 – 99 minutes (0 = do not to turn off) (back-light life is 50 thousand hours at 25°C)	
Resolution	160 x 32 pixels	128 x 64 pixels
Display Range	72 mm (W) x 22 mm (H)	67 mm (W) x 32 mm (H); 3.00" (diagonal preferred)
Contrast Adjustment	15-step contrast adjustment	10-step contrast adjustment
Language Font	ASCII: characters (including European Fonts) Taiwan: (BIG 5 code) traditional Chinese character font China: (GB2324-80 code) simplified Chinese character font	
Font Size (ASCII)	5 x 8, 8 x 8, 8 x 12, 8 x 16	
ALARM Indication LED	1. Power-on indication (Flash three times) 2. Flash for communication error or other alarm 3. Special indication by user programming	
RS-232 LED (Yellow)	Flashes when communicating	
RS-485 LED (Green)	Flashes when communicating	
Program Memory		
Program Memory	256KB flash memory	
External Interface		
Serial Communication Port RS-232 (COM1) 9 PIN D-SUB male	Data length: 7 or 8 bits Stop bits: 1 or 2 bits Parity: None/Odd/Even Baud Rate: 4800 bps – 115200 bps	
Extension Communication port RS-485 (COM2) 5-Pin Removal Terminal (RS-485 or RS-422)	Data length: 7 or 8 bits Stop bits: 1 or 2 bits Parity: None/Odd/Even Baud Rate: 4800 bps – 115200 bps	
Extension Slot	The slot for program copy card	
Power	24V DC input	

Product Selection

Table 48-2. Graphics Panels

Description	Catalog Number	Price U.S. \$
160 x 32 pixels, 10 Function Keys, Monochrome	ELC-GP02	
128 x 64 pixels, 10 Function Keys, Monochrome	ELC-GP04	
Spare Parts Kit (includes several power connectors, battery doors, gaskets, mounting clips, etc.)	ELC-GPSPKIT	

Discount Symbol 2CD-5

Standards and Certifications

Table 48-3. Approvals/Certifications

Description	Specifications
Electrical/EMC	
Electrostatic Discharge Immunity	EN61000-4-2/1995
Radiated Immunity	EN61000-4-3/1995
Electrical Fast Transient	EN61000-4-4/1995
Radiated Emission	CISPR22, Class A
Other Approvals	
Waterproof Class of Front Panel	UL Type 4X Outdoor Rated
Agency Certifications	UL 508, cUL (CSA C22.2 No. 14); CE (Low Voltage Directive); Class 1 Div 2 Groups A, B, C, D

Technical Data and Specifications

Table 48-4. Environmental Ratings/Specifications

Description	Specification
Transportation & Storage	
Temperature	-4° – 140°F (-20° – 60°C)
Operating	
Temperature	32° – 122°F (0° – 50°C)
Humidity	20 – 90% RH (non-condensing)
Communication Interface	COM1: RS-232; COM2: RS-485/RS-422
Vibration	0.5 mm displacement, 10 – 55 Hz, X, Y, Z three directions and two hours for each direction
Impact	10G, 11 mS, from X, Y, Z three directions and three times for each direction
Weight	0.53 Lbs. (0.24 kg)
Cooling Method	Natural Air Cooling

ELCSoftGP Programming Software

ELCSoftGP Programming Software configures all ELC graphic panels. With ELCSoftGP, applications can be created, edited, downloaded, uploaded, etc. Move programs from one controller to a different one with ease.

Requirements:

- **Operating Systems** – Windows 98, Windows ME, Windows 2000, Windows XP
- **Hard Drive** – At least 100M bytes
- **RAM** – At least 256M bytes

Accessories

ELC-GPXFERMOD Program Transfer Module

The ELC-GPXFERMOD is a multifunction device that provides the ability to back up an application already loaded onto one of the ELC-GPxx units. It will store all system settings like baud, ID, etc., as well as passwords and the application itself. Once stored in the module, the application and settings can be transferred to another ELC-GPxx unit of the same model number.

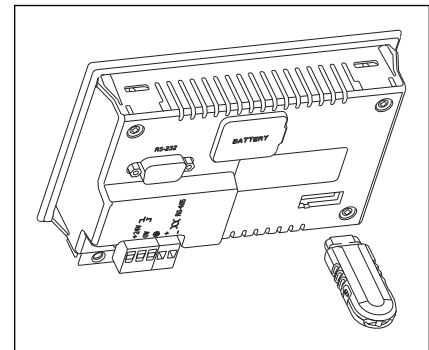
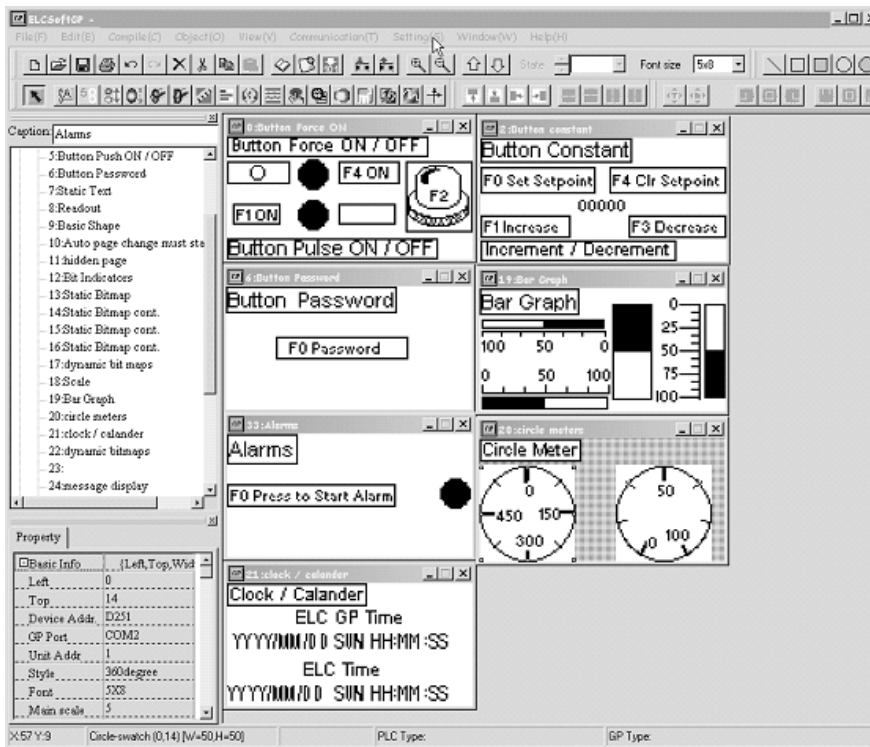

Figure 48-1. ELC-GPXFERMOD



ELCSoftGP Editing Environment

ELC-CBPCGP3 Cable

Use this cable to download or upload applications between a PC and the ELC-GPxx graphics panels. This cable can also be used to transfer a program from an ELC-GPxx to another ELC-GPxx. This cable is 3 meters long.

- The Pin definition of 9 PIN D-SUB RS-232:

ELC-GP04 COM Port RS-232 9 PIN D-SUB Male	
3	Tx
2	Rx
5	GND

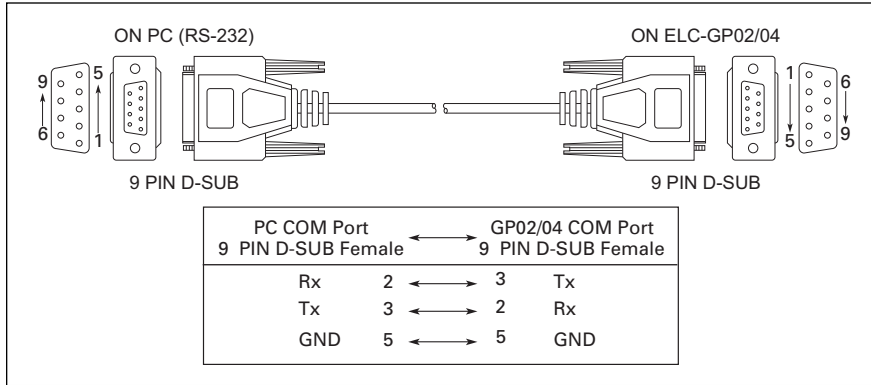

Figure 48-2. PC to ELC-GPxx Cable

ELC Power Supplies

All ELC modules operate from 24V DC. These power supplies provide a convenient way to provide robust DC voltage.

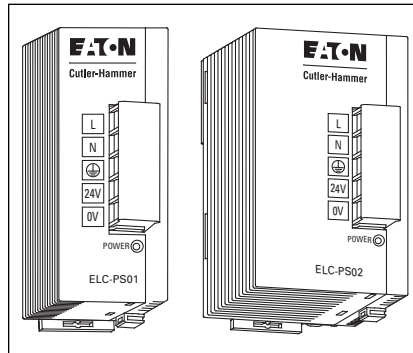

Figure 48-3. ELC Power Supplies

Table 48-5. ELC Power Supply Specifications

Item	ELC-PS01	ELC-PS02
Dimensions W x H x D in Inches (mm)	1.44 x 3.54 x 2.36 (36.5 x 90 x 60)	2.17 x 3.54 x 2.36 (55 x 90 x 60)
Input Power	100 – 240V AC 50/60 Hz	
Output Volts	24V DC	
Output Current (A)	1A	2A
Watts	24	48

Product Selection

Table 48-6. Software and Accessories

Description	Catalog Number	Price U.S. \$
Programming Software for GP Units	ELCSOFTGP	
Program Transfer Module	ELC-GPXFERMOD	
Cable, PC to ELC-GPxx, 9.8 ft. (3 m)	ELC-CBPCGP3	
Power Supply, 24 Watt, 1 Amp	ELC-PS01	
Power Supply, 48 Watt, 2 Amp	ELC-PS02	

Dimensions

Dimensions

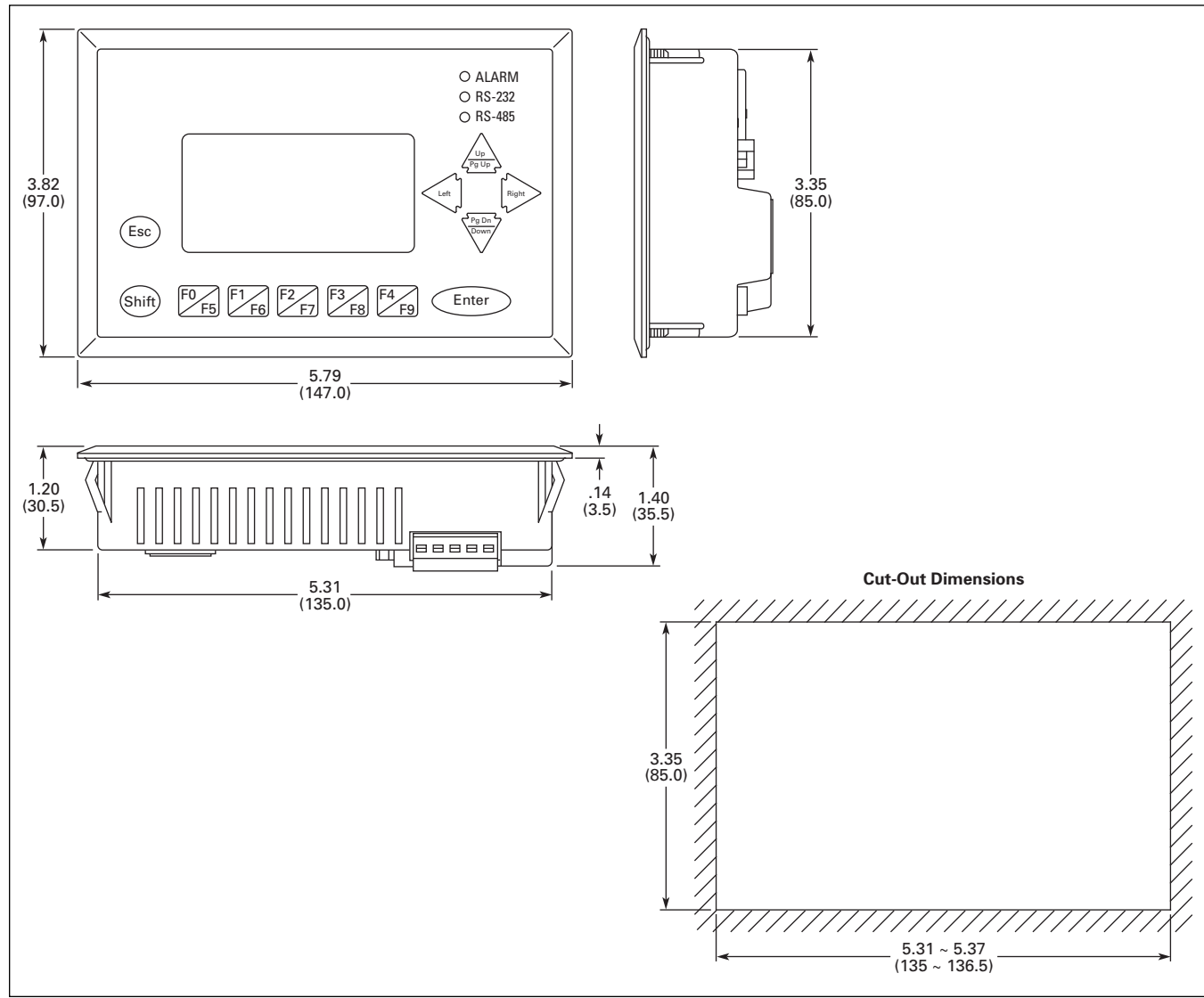

Figure 48-4. ECL-GP04 — Approximate Dimensions in Inches (mm)

Dimensions

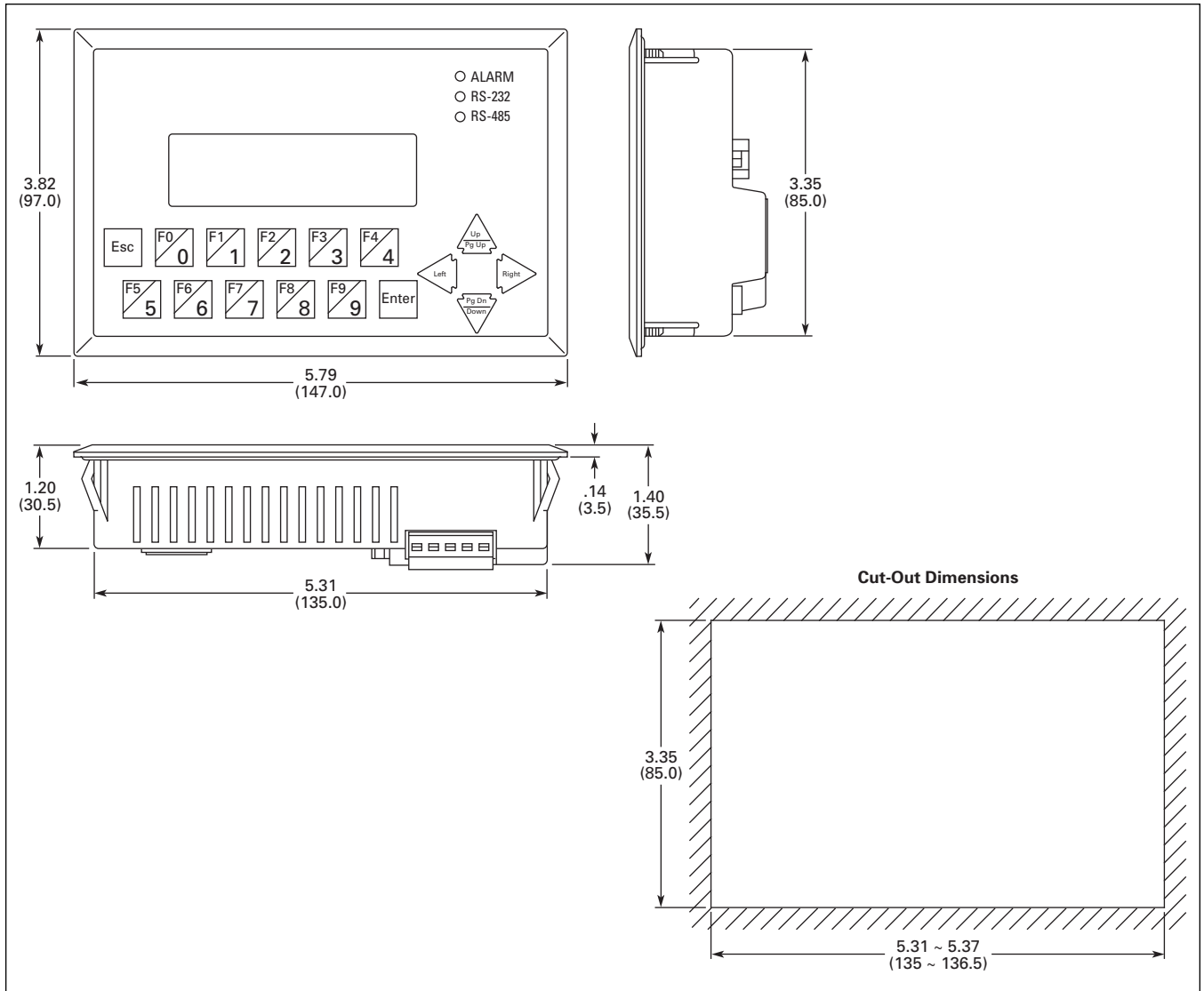

Figure 48-5. ECL-GP02 — Approximate Dimensions in Inches (mm)

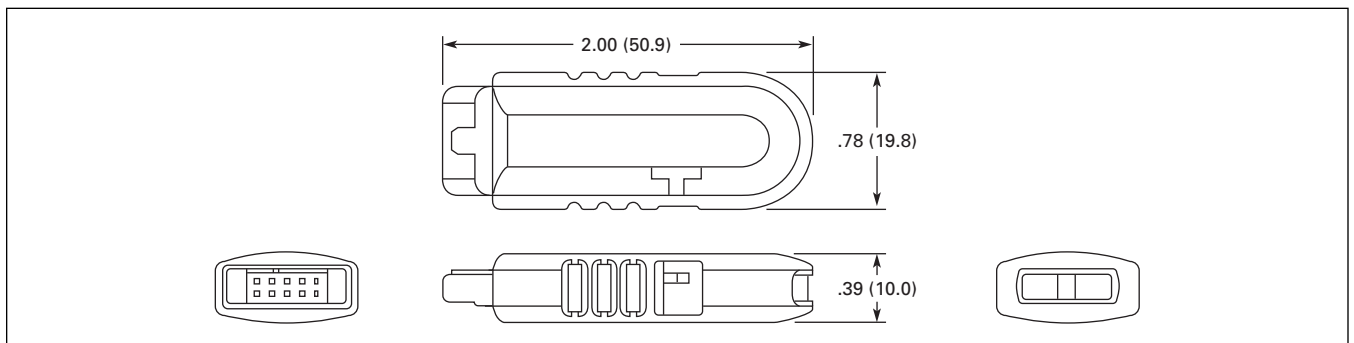

Figure 48-6. ELC-GPXFERMOD — Approximate Dimensions in Inches (mm)

HMI Operator Interface

Product Description

Positioned between the ELC graphics panels and the ePro series of operator interfaces, **HMI** is the work horse of the industry. All units feature a touch-screen and function keys to suit all environments and applications. They range in screen size and color to fit available space and application needs. All units offer RS-232, RS-485 and RS-422 communications. The 6", 8" and 10" units also offer Ethernet communication with an accessory card.



Features

- Analog Touchscreen
- Auto-scale application from 10" to 4"
- Screen Saver
- Pop-up Screens
- Animated Graphics
- Ethernet Modbus TCP Communication Drivers
- Ethernet and USB Upload/Download
- USB Ports for Data Storage
- 3 Serial Ports
- 3 Simultaneous Protocols
- Embedded Logic for use with Local I/O
- Math and Logic Functions
- Clock Synchronization
- Recipes
- Macro Capability
- Data Archiving
- Alarm/Event Recording and Viewing
- Real-time and Historical Trending
- Multi-Language
- 8 Levels of Security
- On and Off-line Simulation

Protocols Supported

Table 48-7. Protocols Supported by HMI

Manufacturer	Protocol
Allen-Bradley	MicroLogix SLC 500
Danfoss	VLT 2800 (FC Protocol)
Eaton	ELC Series
Facon	FB Series
Festo	Festo PLC
GE Fanuc	90 Series SNP
Hust	Hust CNC Controller Hust CNC Controller v2
Jetter	Nano Series
Keyence	KV/KZ Series
Koyo	DL/SU Series K-Sequence
Lenze	LECOM-A/B protocol
LG	Master-K 120S/200S Glofa GM6 CNET Master-K CNET
Li Yan	LYPLC EX
M2i	M2i Master M2i Slave
Matsushita	FP Series
Mirle	FAMA SC
Mitsubishi	FX Series FX2N A Series/J71UC24 A2A/A2AS/A2USH A1SH/A3N/A2ASH CPU Port Q Series CPU Port

Manufacturer	Protocol
MKS	CT150
Modbus	ASCII (Master) 984 RTU (Master) RTU 2W (Master) ASCII Hex Address (Master) RTU Hex Address (Master) ASCII nW (Master) RTU nW (Master) ASCII (Slave) RTU (Slave)
Modicon	TSX Micro (Uni-Telway) NEZA (Uni-Telway) TWINDO
NIKKI DENSO	NCS-FI/FS Series
Omron	C Series CJ1 Series TPM1A
SIEMENS	S7 200 S7 300 (with PC Adapter) S7 300 (without PC Adapter)
Taian	TP02
Ti	Ti435
Vigor	M Series
VIPA	S7 300 (with PC Adapter)
YOKOGAWA	ACE

Product Selection

Table 48-8. HMI Product Selection

Description	Catalog Number ①	Price U.S. \$
4" Blue Mode Touchscreen	HMI04BU	
6" Blue Mode with Expansion Slot	HMI06BE	
6" Gray Scale Mode with Expansion Slot	HMI06GE	
6" Color Mode with Expansion Slot	HMI06CE	
8" Color Mode with Expansion Slot	HMI08CE	
10" Color Mode with Expansion Slot	HMI10CE	

① Add suffix -B for Blank Bezel (Eaton Logo Removed). Example: HMI04BU-B
Add suffix -BF for Blank Bezel with Function Buttons. Example: HMI06CE-BF
Contact Factory for Custom Bezel.

Technical Data and Specifications
Table 48-9. Specifications

Model	HMI04BU	HMI06BE	HMI06GE	HMI06CE	HMI08CE	HMI10CE
Display Type	STN	STN	FSTN	STN	TFT-LCD	
Display Color	8 Blues	8 Blues	16 Grays	256 Colors	65536 Colors	
Screen Pixels	320 x 240 pixels	320 x 240 pixels			640 x 480 pixels	
Back-light Life	About 20,000 hours at 25°C	About 50,000 hours at 25°C			About 30,000 hours at 25°C	
Display Size	3.8"	5.7" (118.2 x 89.4 mm)			8.0" (162.2 x 121.77 mm)	10.4" (215.2 x 162.4 mm)
Operation System	Real Time OS					
MCU	32-bit RISC Micro-controller / 206.4 MHz					
Memory						
Program	1M	3M	3M	3M	7M	7M
History	120K	360K	360K	360K	360K	360K
Recipe	64K ^②	128K	128K	128K	128K	128K
Alarm	4K	16K	16K	16K	16K	16K
Data Registers						
Volatile	64K	64K	64K	64K	64K	64K
Non-volatile	1K	1K	1K	1K	1K	1K
Backup Memory (Bytes)	128K	512K			512K	512K
Ext. Memory	SM Card	✓	✓	✓	✓	✓
	USB Disk	✓			✓	✓
Extension Interface		✓	✓	✓	✓	✓
USB for Download (USB Client)	1 Client Ver. 1.1					
USB for Data Storage / Printer (USB Host)	✓				✓	✓
LCD Module	LED Back Light	CCFL Back Light	CCFL Back Light	CCFL Back Light	CCFL Back Light	2CCFL Back Light
Function Key	4	4	4	4	6	7
Perpetual Calendar (RTC)	Built-In					
Cooling Method	Natural Air Circulation					
Standards and Certifications	IP65 / UL Type 4X (Indoor Only) / CE / UL / cUL / C-Tick					
Operating Temp.	32° – 122°F (0° – 50°C)					
Storage Temp.	-4° – 140°F (-20° – 60°C)					
Ambient Humidity	10% – 90% RH (0 – 40°C), 10% – 55% RH (41 – 50°C)					
Shock	30G @ 11 mS					
Vibration Resistance	IEC61131-2 compliant When vibration is NOT continuous: 5 Hz – 9 Hz 3.5 mm, 9 Hz – 150 Hz 1G X, Y, Z directions for 10 times					
Dimensions (W) x (H) x (D) in Inches (mm)	5.54 x 4.13 x 1.76 (140.8 x 104.8 x 44.8)	7.25 x 5.67 x 1.85 (184.1 x 144.1 x 47)			9.57 x 7.01 x 2.06 (243.1 x 178.1 x 52.4)	11.70 x 8.74 x 2.01 (297.1 x 222.1 x 51.1)
Weight in Lbs. (kg)	.69 (.315)	1.69 (.768)			2.52 (1.147)	3.79 (1.721)
Backup Battery	3V Lithium Battery CR2032 x 1 / Battery Life: 5 Years					
Buzzer	85dB					
Operation Voltage	DC +24V (10% – 20%) (Please use isolated power supply) ^①					
Wattage	2.64	7.2	7.2	7.2	14	15
NIT Rating	100 cd/m ²	130 cd/m ²		100 cd/m ²	400 cd/m ²	330 cd/m ²

^① Please use isolated power supply (not applicable for HMI08CE and HMI10CE).

^② Recipe memory uses program memory.

Software and Accessories

HM*i*soft Programming Software

For use with the HM*i* series of touch-screens, this software supports all of the features of HM*i* (listed on **Page 48-8**). This easy to use Windows-based software can run on Windows 2000 and XP with a minimum CPU of Pentium III 500 Mhz, 256 MB RAM, 100 MB free hard disk space and mouse.

- Simulate an application on or off line
- Built in picture library
- Create your own picture library
- Screen manager
- 70 on-screen object
- Easy object setup
- Monitor all states of objects
- Macro editing
- Scale application from 10" – 4"
- Upload/download applications over USB
- Upload/download register data over USB
- Logic configuration for I/O expansion modules
- Ethernet communications

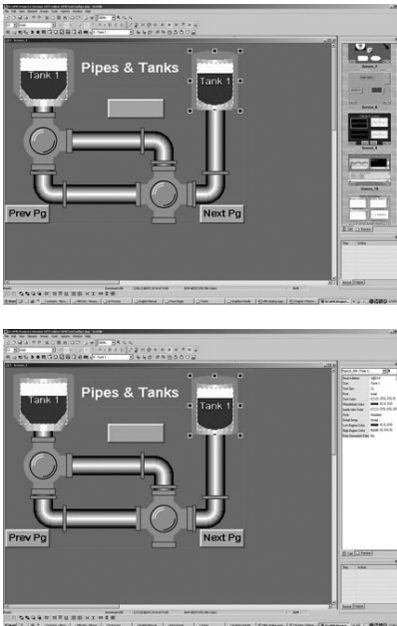

HMI Editor

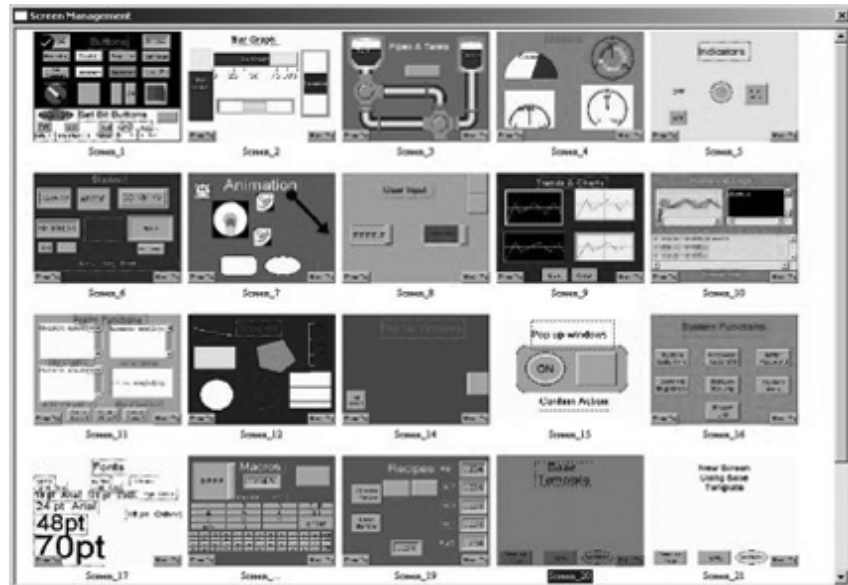

HMI Screen Management

Accessories

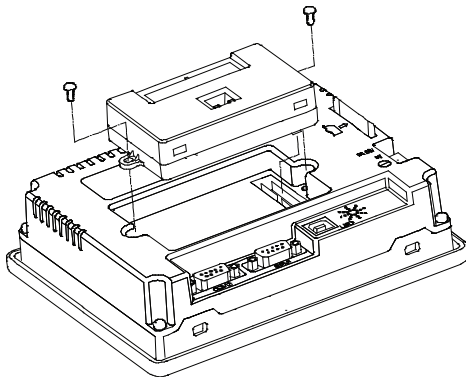

HMIECENT Ethernet Expansion Module

Ethernet Expansion Module

The HMIECENT expansion module adds 10/100 MB Modbus TCP ability when plugged into the expansion slot of a 6", 8" or 10" HMI unit. Up load and download programs and communicate to other Modbus TCP devices. No need for patch or crossover cables as this module auto-detects and adjusts for proper operation.

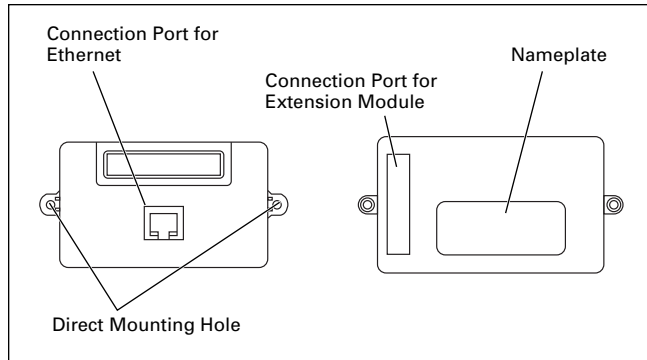

Figure 48-7. Ethernet Expansion Module — Product Outline

Table 48-10. HMIECENT Function Specifications

Item	Specifications
Power Supply Voltage	DC 5V ±10%, 1A (provided by HMI)
Interfaced Supported	RJ-45 with Auto MDI/MDIX
Number of Ports	1 Port
Transmission Method (Standard Conformance)	IEEE 802.3, IEEE 802.3u
Transmission Cable	Category 5e (TIA/EIA-568-A, TIA/EIA-568-B)
Transmission Speed	10/100 Mbps Auto Detection
Ethernet Protocol	ICMP, IP, TCP, UDP, DHCP, Modbus TCP
Noise Immunity	ESD (IEC 61131-2, IEC 61000-4-2): 8 kV Air Discharge EFT (IEC 61131-2, IEC 61000-4-4): Power Line: 2 kV, Communication I/O: 1 kV Damped-Oscillatory Wave: Power Line: 1 kV, Digital I/O: 1 kV RS (IEC 61131-2, IEC 61000-4-3): 26MHz ~ 1GHz, 10V/m
Certifications	C-Tick, cULus, CE

I/O Expansion Modules

The HMIEC0806 and HMIEC1612 are 14 and 28 discrete I/O expansion modules providing 8 DC inputs and 6 relay outputs or 16 DC inputs and 12 relay outputs. Plug this module into the available expansion slot on the back of the HMI unit (not available on the 4" model) and it's ready to use. No need for a separate PLC controller as it is built into the unit. Combine operator interface and logic into a single platform — use HMISOFT to build both the ladder logic and OI program.

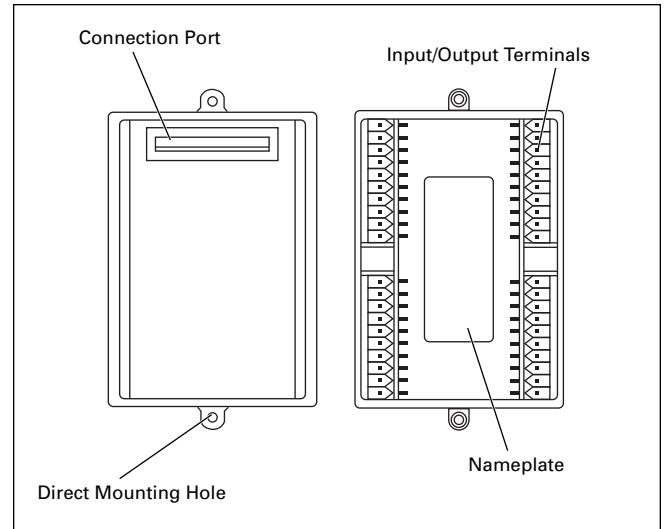

Figure 48-8. I/O Expansion Modules — Product Outline

Table 48-11. I/O Expansion Modules

Catalog Number	Input/Output				
	Power	Input Unit		Output Unit	
		Point	Type	Point	Type
HMIEC0806	5V DC supplied by HMI	8	DC Type Sink or Source	6	Relay
HMIEC1612		16		12	

Software and Accessories

Table 48-12. HMIEC0806/HMIEC1612 Function Specifications

Item		Specifications	Remark
Control Method		Stored program, cyclic scan system	—
I/O Processing Method		Batch I/O (refresh)	Immediate refresh command available only with I/O of the MPU
Execution Speed		Basic command (30 us)	Application command (30 ~ hundreds us)
Program Language		Commands + Ladder Diagram + SFC	Step commands included
Program Capacity		999 Steps	Built-in EEPROM
Commands		Basic commands: 32 (including the STL commands)	Application commands: 59
Step Relay (Latched)	General Step Point	128 Points	S0 ~ S127
Auxiliary Relay	General	1024 Points	M0 ~ M511, M768 ~ M999, 744 points; M1000 ~ M1279, 280 points ①
	Latched	256 Points	M512 ~ M767
Timer	Digital	64 Points	T0 ~ T63 (100 ms time base)
		63 Points	T64 ~ T126 (10 ms time base)
		1 Points	T127 (1 ms time base)
Counter	General	112 Points	C0 ~ C111
	Latched	16 Points	C112 ~ C127
	32 bit	13 Points	C235, C236, C237, C238, C241, C242, C244, C246, C247, C249, C251, C252, C254 (all of them are latched type)
Data Register	General	408 Points	D0 ~ D407
	Latched	192 Points	D408 ~ D599
Pointer	P	64 Points	P0 ~ P63
Index Register	E / F	2	E, F
Constant	Decimal K	16 bit: -32768 ~ +32767	32 bit: -2147483648 ~ +2147483647
	Hexadecimal H	16 bit: 0000 ~ FFFF	32 bit: 00000000 ~ FFFFFFFF
Self Diagnosis / Protection		I/O check, system execution timeout check, invalid command check, program check and password settings	
Monitor / Debug		Program execution time display, bit / word, device settings	
Certifications		C-Tick, cULus, CE	

① M1000, M1001, M1002, M1003, M1020, M1021, M1022, M1067, M10068, and M1161 are the special auxiliary relays (special M).

Table 48-13. HMIEC0806/HMIEC1612 Electrical Specifications

Item / Model Name	HMIEC0806	HMIEC1612
Power Supply Voltage	5V DC, 1A (supplied by HMI)	
Power Consumption	0.25W	0.5W
Noise Immunity RS CS ESD EFT Surge	Frequency: 80MHz ~ 1GHz, 1.4GHz ~ 2.0GHz, Test level 10V/m Frequency: 0.15MHz ~ 80MHz, Test level 10V (HMI power port & I/O line) Air discharge ±8 kV ±1.5 kV (HMI power port), ± 1 kV (I/O line) ±2 kV (HMI power port)	
Ambient Temperature/Humidity	Operation: 0°C ~ 50°C (Temperature), 10 ~ 90% (Humidity), Storage: -40°C ~ 85°C (Temperature), 10 ~ 90% (Humidity)	
Vibration / Shock	IEC 61131-2 Compliant 5 Hz ≤ f < 9 Hz = Continuous: 1.75mm / Occasional: 3.5mm 9 Hz ≤ f ≤ 150 Hz = Continuous: 0.5g / Occasional: 1.0g X, Y, Z directions for 10 times	
Weight	Approx. 95.5g	Approx. 116g

Input Point Electric Specifications

Input Type	DC (SINK or SOURCE)
Input Voltage	24V DC (5mA)
Active Level	Off → On, above 16V DC On → Off, below 14.4V DC
Response Time	Approx. 10 mS

Output Point Electric Specifications

Output Type	Relay-R
Current Specifications	1.5A / 1 Point (5A/COM)
Voltage Specifications	250V AC, below 30V DC
Maximum Loading	75 VA (Inductive), 90W (Resistive)
Response Time	Approx. 10 mS
Mechanical Life	2 – 107 times (without load)
Electrical Life	100,000 times (3A 250V AC/30V DC) 6,000 times (5A 250V AC/30V DC)

Product Selection

Table 48-14. Product Selection — Software and Accessories

Description	Catalog Number	Price U.S. \$
Programming Software	HMISOFT	
Ethernet Modbus TCP Expansion Module	HMIECENT	
I/O Expansion Module, 8 In/6 Out	HMIEC0806	
I/O Expansion Module, 16 In/12 Out	HMIEC1612	
6" HMI Adapter Plate for PM1000	APPM1HMI6	
8" Anti-Glare Overlay Kit (5/kit)	17AGT	
8" Clear Protective Overlay Kit (5/kit)	17CPT	
10" Anti-Glare Overlay Kit (5/kit)	39AG	
10" Clear Protective Overlay Kit (5/kit)	39CP	
HMI Spare Parts Kits (includes several power connectors, battery doors, gaskets, mounting clips, etc.)	HMI-SPKIT	
4" HMI Replacement Gasket (2/kit)	HMI04-GASKET	
6" HMI Replacement Gasket (2/kit)	HMI06-GASKET	
8" HMI Replacement Gasket (2/kit)	HMI08-GASKET	
10" HMI Replacement Gasket (2/kit)	HMI10-GASKET	

Dimensions

Dimensions

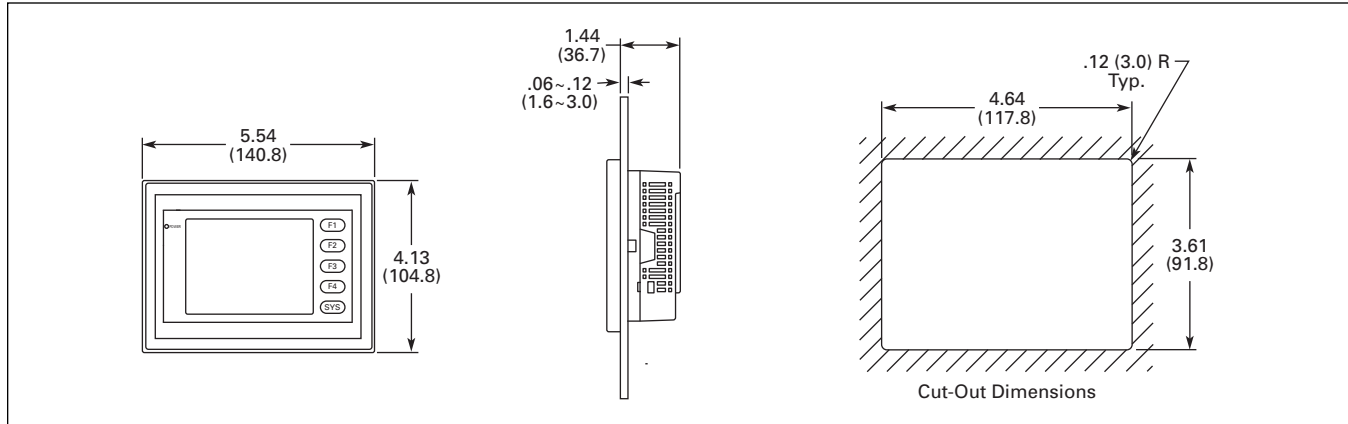
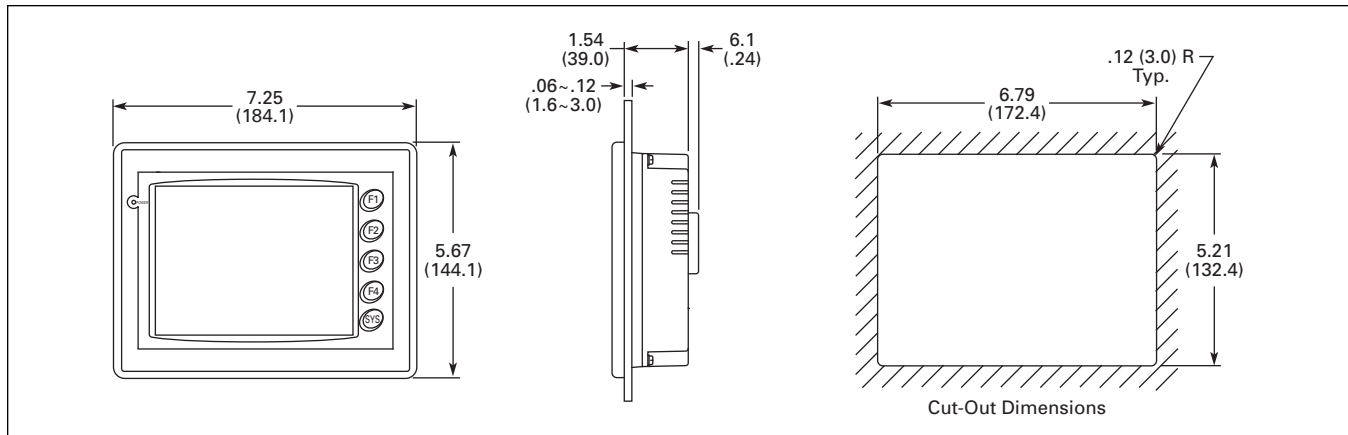

Figure 48-9. HMI04 — Approximate Dimensions in Inches (mm)



48

Figure 48-10. HMI06 — Approximate Dimensions in Inches (mm)

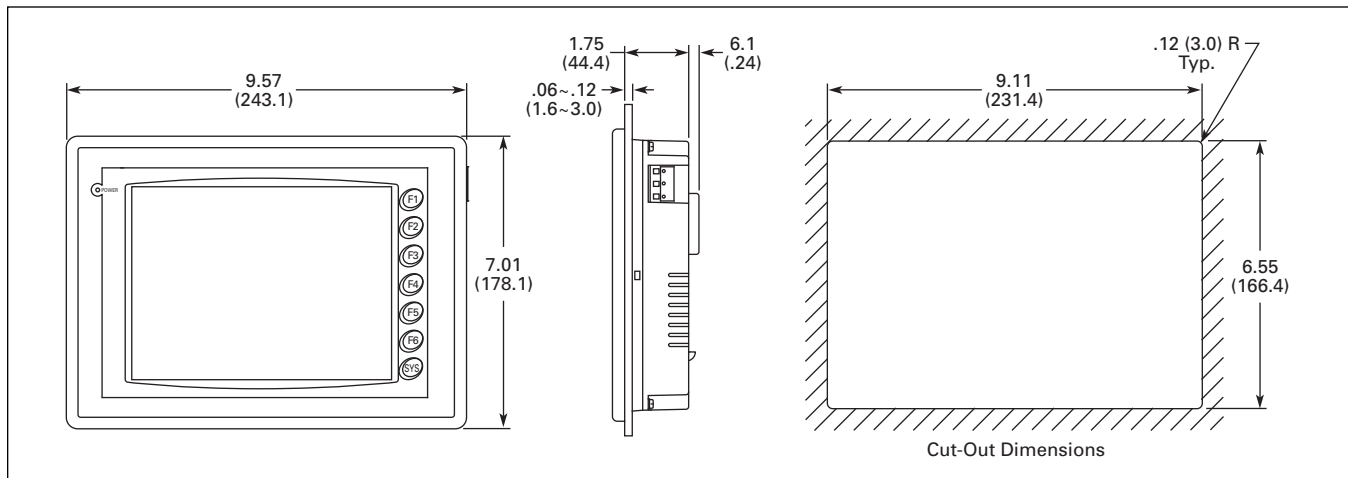

Figure 48-11. HMI08CE — Approximate Dimensions in Inches (mm)

Dimensions

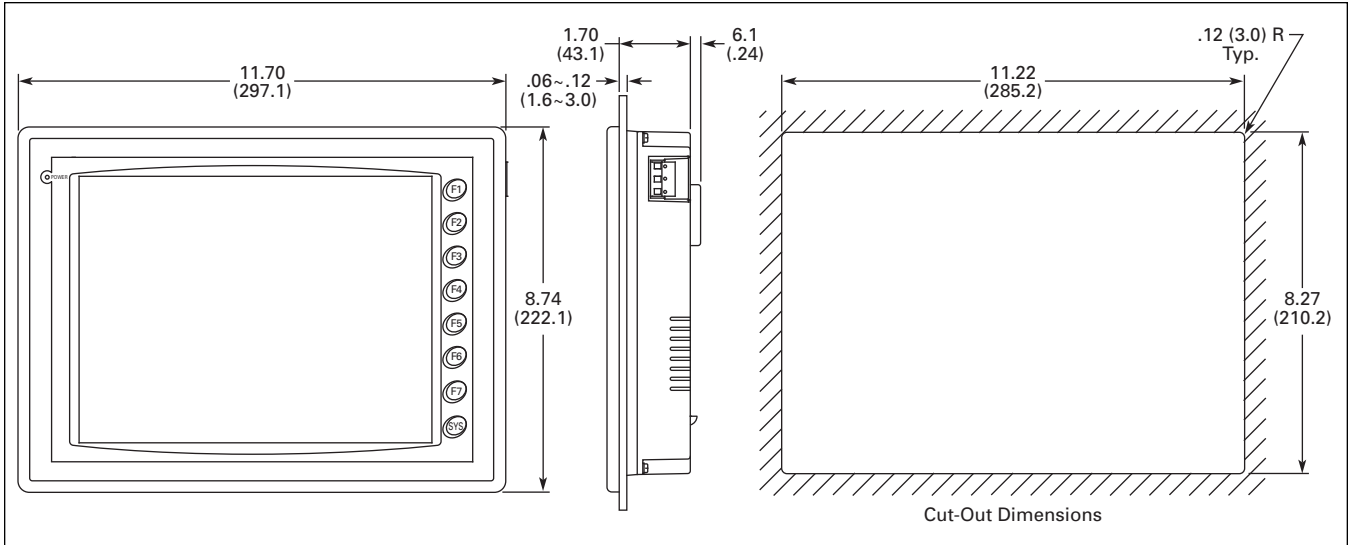

Figure 48-12. HMI10CE — Approximate Dimensions in Inches (mm)

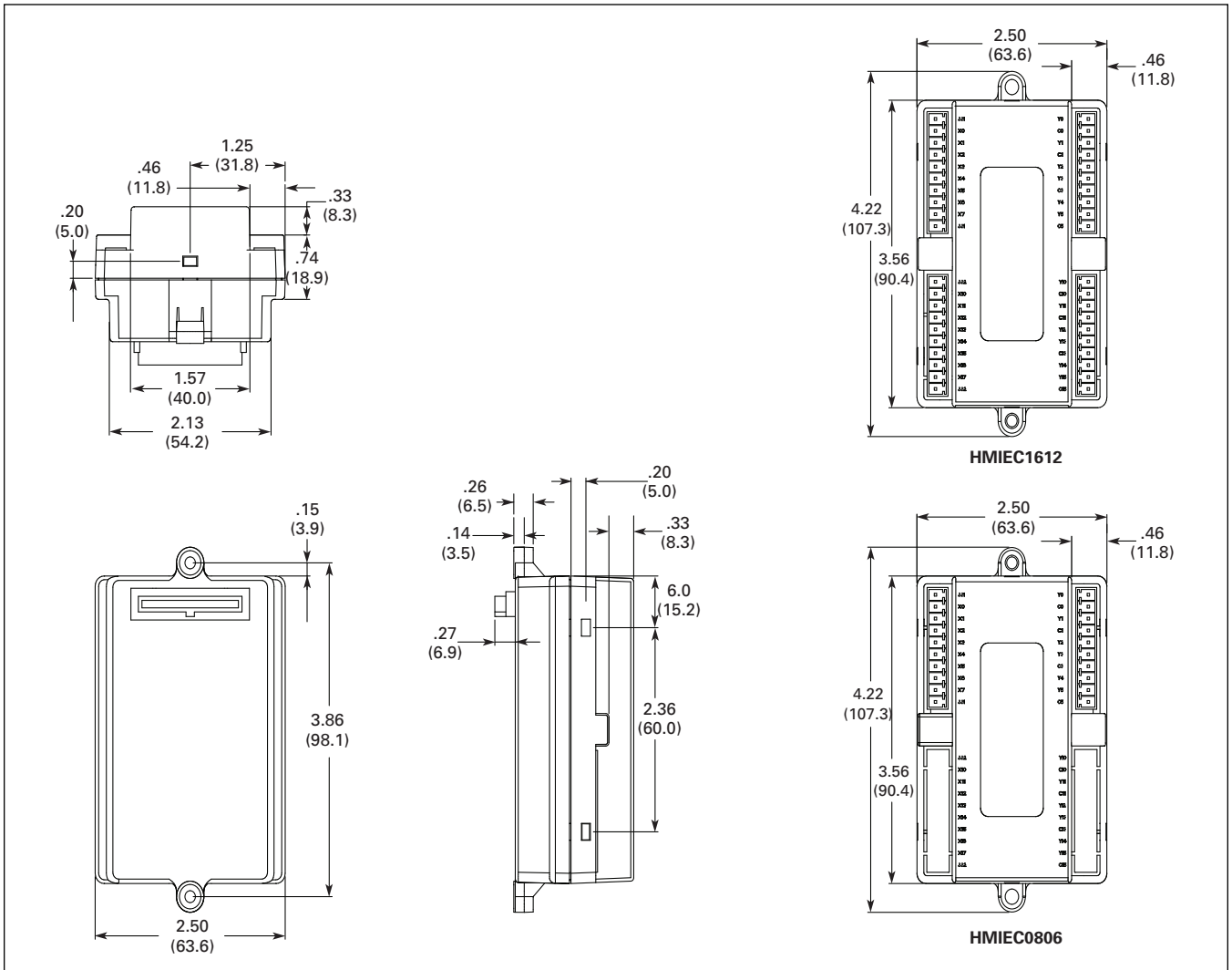

Figure 48-13. HMIEC0806 and HMIEC1612 Expansion Modules — Approximate Dimensions in Inches (mm)

Dimensions

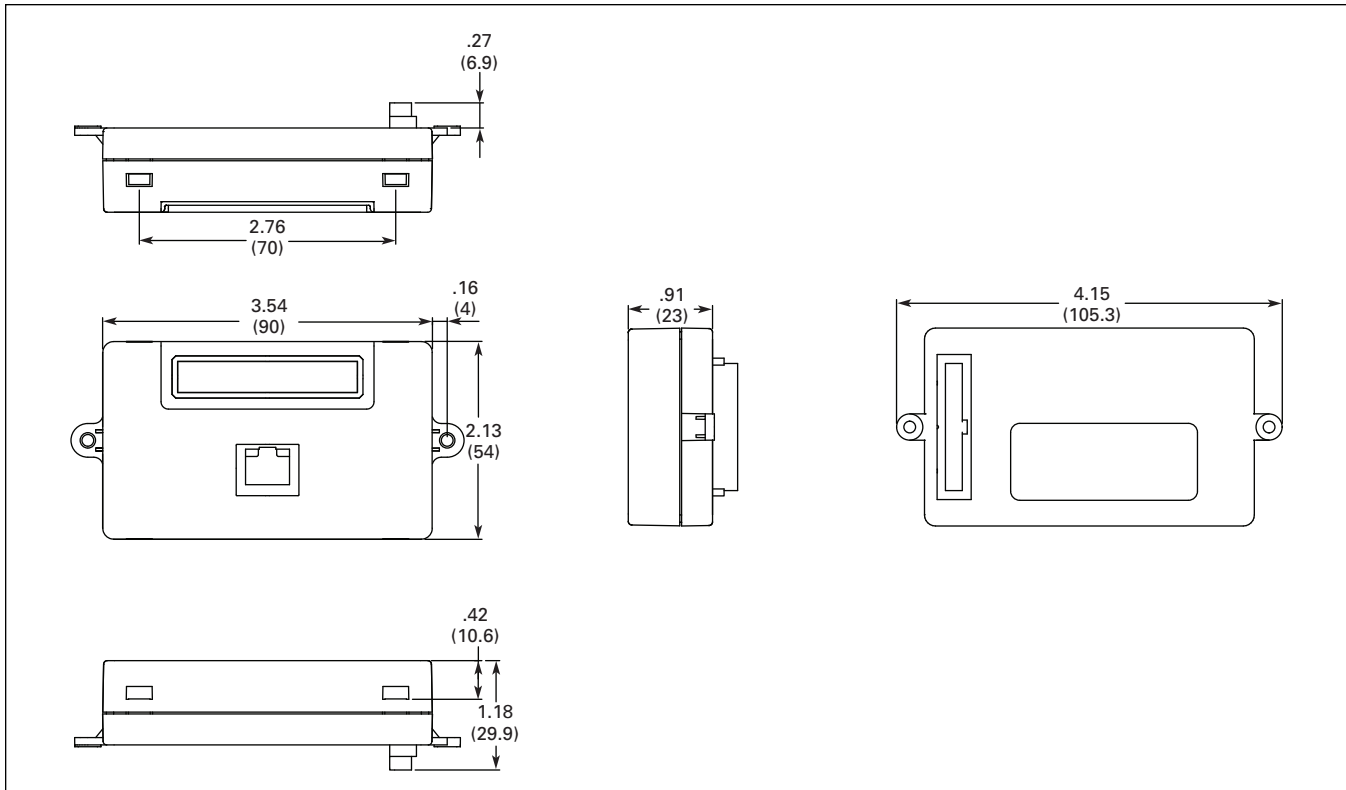

Figure 48-14. HMIECENT Ethernet Expansion Module — Approximate Dimensions in Inches (mm)

Product Family Overview

Product Family Overview

Machine builders and manufacturing system designers increasingly recognize the benefits of using electronic operator interface devices to replace pushbuttons, lights, gauges and other traditional hardwired devices.

Most choose dedicated operator interface systems because they are easy to use, fully integrated and cost-effective.

PanelMate: The Industry Standard

PanelMate units are flexible, expandable, cost-effective alternatives to traditional operator control panels. A single PanelMate unit easily replaces panels that once contained numerous pushbuttons, indicator lights, thumbwheels, message displays and alarm annunciators.

PanelMate Technology Benefits

- Replaces conventional control panels at less than half the cost.
- Gives operators more information for better control decisions.
- Standardizes operator stations and minimizes operator training.
- Saves processor memory by utilizing Boolean logic and math functions.
- Reduces hardwiring costs and minimizes installation time.
- Adds advanced capabilities such as machine diagnostics, troubleshooting, trending and alarms at no additional cost.
- Automates documentation.
- Meets tight panel space requirements.

How to Select

PanelMate System Components

Each PanelMate system requires component selection from three major categories:

- Operator Interface — the online unit or operator station.
- Configuration Software — PC-based software, used to configure and transfer applications to and from the Operator Interface.
- Connectivity — includes optional cables, hardware interfaces and software utilities.

Selection Criteria

- First, select the most appropriate Operator Interface, Display Type and Size, and Operator Input options for the customer's application.
 - The selection of the Operator Interface model line is driven by such considerations as the size and complexity of the operator interface application, performance requirements, as well as the economic factors of the overall control system.
 - The Display Type is chosen based on the operator's needs — text only, text and graphics, color or grayscale. Display Size is selected based on application complexity and the operator's proximity to the Operator Interface.
 - Operator Input options include either touchpanel (keypad) or touchscreen Operator Interface models. Criteria for selection of the best input method include environmental factors (airborne particles, grease, etc.), and application design (numeric input, one-touch control, etc.).
- Second, select the appropriate configuration editing software for the chosen Operator Interface.

Note: If the customer already has configuration software, they may only need a software upgrade.

- Finally, select required connectivity features, such as interface cables, optional high-speed interface cards, and, for some Allen-Bradley® drivers, licensing enabler utilities.

Eaton's Cutler-Hammer interface cables are ideal for system and application testing. For actual plant floor applications, custom cables are generally required to meet the customer's requirements for length, environment, termination, etc.

Note: In order to specify the proper cabling and other connectivity options, you must know the target PLC or controller to be used with the Operator Interface. Required information may include the PLC brand, Model Number, software/firmware revision level, and hardware/software interface type.

Glossary

- Classic — Support PanelMate Power Pro and Canvas applications
- EE — Enterprise Edition (extended capabilities)
- ePro — PanelMate ePro Series
- ePro PS — PanelMate ePro PS (Performance Series)
- KP — Keypad (Touchpanel)
- OD — Outdoor Series
- PP — PanelMate Power Pro Series
- SST — Stainless Steel Front Panel Option
- TS — Touchscreen

Table 48-15. PanelMate Operator Interface Model Selection Guide

Family	Series	Display	TS ①	KP ①	SST	OD	Classic	EE	Ethernet	Power Pro SW	Canvas SW
ePro PS	7685T-8	8.4" Color TFT	✓			✓	✓	✓	✓	✓ ^③	✓
ePro PS	7685T-10	10.4" Color TFT	✓		✓		✓	✓	✓	✓ ^③	✓
ePro PS	7685T-12 7685T-15	12.1" Color TFT 15.0" Color TFT	✓		✓	✓	✓	✓	✓	✓ ^③	✓
ePro PS	7600	Display with TS or other input device purchased separately.					✓	✓	✓	✓ ^③	✓
PP	1155 1175	7.4" Grayscale LCD 7.7" Color DSTN	✓	✓						✓	
PP	1755 1775 1785	7.4" Grayscale LCD 7.7" Color DSTN 8.4" Color TFT	✓	✓						✓	
PP	3985	10.4" Color TFT	✓	✓	✓					✓	
PP	5485	10.4" Color TFT		✓ ^②	✓					✓	
PP	5785	10.4" Color TFT	✓	✓	✓					✓	

① TS and KP options are mutually exclusive.
 ② Split architecture.
 ③ Classic model required.

ePro PS

PanelMate ePro PS

PanelMate ePro PS

Product Description

The PanelMate ePro PS family is made up of high performance, yet cost-effective operator interface products. The ePro PS family carries on the PanelMate tradition of performance in balance with ease of use. The ePro PS family sets the standard for hybrid OI systems by combining the flexibility of Microsoft® Windows® XP Embedded operating system with the stability and reliability achieved through the solid-state hardware design and exclusive Protect Mode™ that provides protection for the operating system and software.

The ePro PS family provides the performance and flexibility of PC-based operator interfaces without the associated complexity of a PC on the plant floor. With integrated high-speed Ethernet, serial ports, USB ports, removable CompactFlash® and PCMCIA, the ePro PS models can be adapted for a wide variety of user requirements.

The ePro PS family of products are configured with the Canvas® editing software. The Canvas editor supports a modern suite of graphical templates, called controls, for replacing hardwired panel devices such as pushbuttons, indicator lights, bars, readouts, message displays, etc.

The PanelMate ePro PS family of products includes:

- PanelMate ePro PS
- PanelMate ePro PS OD (Outdoor Series)
- PanelMate ePro PS EE (Enterprise Edition)
- PanelMate ePro PS Classic

PanelMate ePro PS OD

The PanelMate ePro PS OD (Outdoor Series) operator interface is designed for use in outdoor applications. The OD models offer increased visibility in high ambient light, broad temperature specifications and UV resistance.

PanelMate ePro PS EE

The PanelMate ePro PS EE (Enterprise Edition) operator interface is designed for end users that need more system memory, more data storage or additional Windows XP Embedded components and services to support large Canvas applications or third-party software.

PanelMate ePro PS Classic

The PanelMate ePro PS Classic operator interface is designed for use by end users that are currently using the PanelMate Power Pro software and are ready for the new PanelMate ePro PS hardware but are not quite ready to convert their PanelMate Power Pro configurations to Canvas applications. Since the PanelMate ePro PS Classic OI supports Power Pro and Canvas Runtime software, the user can utilize the Canvas Runtime software if and when they are ready.

The ePro PS Classic OI is based on the PanelMate ePro PS hardware models with the addition of software and licenses that allow users to run the PanelMate Power Pro Runtime software. One difference is in the area of drivers: the ePro PS Classic OI running PanelMate Power Pro configurations does not support native (non-OPC) communication drivers, but does support up to three OPC drivers simultaneously.

Application Description

Whether replacing hard-wired pilot devices and pushbuttons or providing machine control and even SCADA functions, the ePro PS family of products will fit from both a form and functional standpoint. In monitoring and diagnostic applications, as well as operator controls for critical start/stop, ramp/jog and set point adjustment, the PanelMate ePro PS products offer a reliable and safe interface for a wide range of industrial applications such as:

- Discrete manufacturing machine diagnostics and controls
- Oil platform monitoring and control in the petroleum industry
- Central and remote water and wastewater control panels
- Monitoring and control panels for local facilities/air handling equipment
- Tire manufacturing mixing and building processes
- Industrial and commercial power house controls; building HVAC controls
- Material handling and palletizing monitoring and control
- Automotive press and machine parts controls

Features

Table 48-16. PanelMate ePro PS Features

Feature	Description
8" Display Models	<ul style="list-style-type: none"> ■ 8.40" (213.4 mm), color TFT display, 16 million colors ■ SVGA (800 x 600) resolution ■ 400 nits (400 cd/m²), OD Models 425 nits (425 cd/m²) brightness ■ 50,000 hours typical life for backlight; field replaceable ■ Auto dimming
10" Display Models	<ul style="list-style-type: none"> ■ 10.40" (260 mm), color TFT display, 16 million colors ■ SVGA (800 x 600) resolution ■ 420 nits (420 cd/m²) brightness ■ 50,000 hours typical life for backlight; field replaceable ■ Auto dimming
12" Display Models	<ul style="list-style-type: none"> ■ 12.10" (307.3 mm), color TFT display, 16 million colors ■ SVGA (800 x 600) resolution ■ 450 nits (450 cd/m²), OD Models 505 nits (505 cd/m²) brightness ■ 50,000 hours typical life for backlight, field replaceable ■ Auto dimming
15" Display Models	<ul style="list-style-type: none"> ■ 15.00" (381.0 mm), color TFT display, 16 million colors ■ XGA (1024 x 768) resolution ■ 250 nits (250 cd/m²), OD Models 600 nits (600 cd/m²) brightness ■ 50,000 hours typical life for backlight, field replaceable ■ Auto dimming
Blind Node (No Display) Models	<ul style="list-style-type: none"> ■ VGA (640 x 480), SVGA (800 x 600), XGA (1024 x 768), SXGA (1280 x 1024), UXGA (1600 x 1200) resolution ■ 16 million colors (SXGA and UXGA — 65K colors)
Operator Entry	<ul style="list-style-type: none"> ■ Touchscreen interface with resistive technology for gloved-hand operation ■ Pop-up, on-screen alphanumeric keypad support
Hardware/Mounting	<ul style="list-style-type: none"> ■ Single-piece lightweight design for easy panel mounting (except blind node models)
Powerful OI Capabilities	<ul style="list-style-type: none"> ■ Supports Canvas controls ■ Built-in two-touch control ■ Full math and logic expressions
Communications and I/O Capabilities	<ul style="list-style-type: none"> ■ One integrated Ethernet port: 10/100Base-T ■ Two serial ports: RS-232 and RS-232/422/485 (optically isolated) ■ Four USB ports: V2.0 ■ One CompactFlash® memory card slot ■ Two PCMCIA Type II slots (or one Type III) ■ Built-in OPC Client/Server with support for over 100 OPC drivers for both Ethernet and serial connectivity ■ One video output port
Protect Mode	<ul style="list-style-type: none"> ■ Safeguards the integrity of operating system files and data files by preventing unauthorized alterations and corruption caused by viruses or unexpected power disruptions

Technical Data

Table 48-17. PanelMate ePro PS Technical Data

Description	Specification
Memory	PS, OD and Classic Models: 512 MB DDR2 RAM, 1 GB Internal CompactFlash (C and D drive) EE Models: 1 GB DDR2 RAM, 4 GB Internal CompactFlash (C drive), 512 MB external CompactFlash (D drive) All Models: External CompactFlash card slot, USB and PCMCIA ports available for additional memory
Voltage	24V DC Nominal (16 – 30V DC)
Power Consumption/ Heat Output	8" Display Models: 31 watts (105 BTU/hour) 10" Display Models: 33 watts (113 BTU/hour) 12" Display Models: 35 watts (120 BTU/hour) 15" Display Models: 54 watts (184 BTU/hour), OD 52 watts (178 BTU/hour) Blind Node (No Display) Models: 24 watts (82 BTU/hour)
Current	8" Display Models: 1.3 amperes 10" Display Models: 1.4 amperes 12" Display Models: 1.5 amperes 15" Display Models: 2.25 amperes Blind Node (No Display) Models: 1.0 amperes
Peak Inrush Current	8" Display Models: 7.0 amperes 10" Display Models: 7.0 amperes 12" Display Models: 7.0 amperes 15" Display Models: 8.0 amperes Blind Node (No Display) Models: 7.0 amperes
Installation Rating	All ePro PS display models are approved for use in Type 4, 4X, 12 and IP65 installations when properly mounted in a correspondingly rated enclosure.
System Ambient Temperature	All Models — ■ Operating: 0 – 60°C [32 – 140°F] ■ Non-operating: -25 to 70°C [-13 to 158°F]
System Vibration	Operating and Non-operating: 1G from 5 – 500 Hz
System Shock	Operating and Non-operating: 100G
Relative Humidity	Operating: 20 – 95% non-condensing Non-operating: 20 – 95% non-condensing
Altitude	Operating: 10,000 ft. (3,048m) above sea level Non-operating: 40,000 ft. (12,192m) above sea level
Emissions	CISPR 11 Class A, Radiated and Conducted
Noise Immunity	IEC 61000-4-2, 3, 4, 5, 6, 8, 11
Agency Certifications	RoHS, CE mark UL/cUL and CSA Class I, Div 2, Groups A, B, C, D
Overall Dimensions (H x W x D)	8" Display Models: 7.63 x 10.51 x 3.90 in. (193.8 x 267.0 x 99.1 mm) 10" Display Models: 12.00 x 12.30 x 3.90 in. (304.8 x 312.4 x 99.1 mm) 12" Display Models: 11.60 x 15.90 x 3.90 in. (294.6 x 403.9 x 99.1 mm) 15" Display Models: 13.50 x 18.60 x 4.00 in. (342.9 x 472.4 x 101.6 mm) Blind Node (No Display) Models: 9.30 x 12.00 x 3.60 in. (236.2 x 304.8 x 91.4 mm)
Cutout Dimensions (H x W)	8" Display Models: 6.50 x 9.38 in. (165.1 x 238.3 mm) 10" Display Models: 11.02 x 11.40 in. (279.9 x 289.6 mm) 12" Display Models: 10.12 x 14.34 in. (257.0 x 364.2 mm) 15" Display Models: 12.05 x 17.01 in. (306.1 x 432.1 mm) Blind Node (No Display) Models: Designed for mounting in a cabinet
Weight	8" Display Models: 6.0 lbs. (2.73 kg) 10" Display Models: 10.5 lbs. (4.77 kg) 12" Display Models: 13.0 lbs. (5.91 kg) 15" Display Models: 17.0 lbs. (7.73 kg) Blind Node (No Display) Models: 4.5 lbs. (2.05 kg)

Product Selection

Table 48-18. PanelMate ePro PS Operator Interface (76xx Series)

Description	Catalog Number	Price U.S. \$
PanelMate ePro PS		
8.4" Color TFT Display, Touchscreen (Acrylic), OPC, DC, User Manual on CD-ROM	7685T-8	
10.4" Color TFT Display, Touchscreen (Glass), OPC, Painted Steel, DC, User Manual on CD-ROM	7685T-10	
10.4" Color TFT Display, Touchscreen (Glass), OPC, Stainless Steel, DC, User Manual on CD-ROM	7685ST-10	
12.1" Color TFT Display, Touchscreen (Glass), OPC, Painted Steel, DC, User Manual on CD-ROM	7685T-12	
12.1" Color TFT Display, Touchscreen (Glass), OPC, Stainless Steel, DC, User Manual on CD-ROM	7685ST-12	
15.0" Color TFT Display, Touchscreen (Glass), OPC, Painted Steel, DC, User Manual on CD-ROM	7685T-15	
15.0" Color TFT Display, Touchscreen (Glass), OPC, Stainless Steel, DC, User Manual on CD-ROM	7685ST-15	
Blind Node (No Display, see Table 48-22 for display options), OPC, DC, User Manual on CD-ROM	7600	
PanelMate ePro PS EE (Enterprise Edition)		
8.4" Color TFT Display, Touchscreen (Acrylic), OPC, DC, User Manual on CD-ROM	7685T-8E	
10.4" Color TFT Display, Touchscreen (Glass), OPC, Painted Steel, DC, User Manual on CD-ROM	7685T-10E	
10.4" Color TFT Display, Touchscreen (Glass), OPC, Stainless Steel, DC, User Manual on CD-ROM	7685ST-10E	
12.1" Color TFT Display, Touchscreen (Glass), OPC, Painted Steel, DC, User Manual on CD-ROM	7685T-12E	
12.1" Color TFT Display, Touchscreen (Glass), OPC, Stainless Steel, DC, User Manual on CD-ROM	7685ST-12E	
15.1" Color TFT Display, Touchscreen (Glass), OPC, Painted Steel, DC, User Manual on CD-ROM	7685T-15E	
15.0" Color TFT Display, Touchscreen (Glass), OPC, Stainless Steel, DC, User Manual on CD-ROM	7685ST-15E	
Blind Node (No Display, see Table 48-22 for display options), OPC, DC, User Manual on CD-ROM	7600E	
PanelMate ePro PS OD (Outdoor)		
8.4" Color TFT Display, Touchscreen (Acrylic), OPC, DC, User Manual on CD-ROM	7685T-8OD	
12.1" Color TFT Display, Touchscreen (Glass), OPC, Painted Steel, DC, User Manual on CD-ROM	7685T-12OD	
12.1" Color TFT Display, Touchscreen (Glass), OPC, Stainless Steel, DC, User Manual on CD-ROM	7685ST-12OD	
15.1" Color TFT Display, Touchscreen (Glass), OPC, Painted Steel, DC, User Manual on CD-ROM	7685T-15OD	
15.1" Color TFT Display, Touchscreen (Glass), OPC, Stainless Steel, DC, User Manual on CD-ROM	7685ST-15OD	
PanelMate ePro PS Classic		
8.4" Color TFT Display, Touchscreen (Acrylic), OPC, DC, User Manual on CD-ROM	7685T-8C	
10.4" Color TFT Display, Touchscreen (Glass), OPC, Painted Steel, DC, User Manual on CD-ROM	7685T-10C	
10.4" Color TFT Display, Touchscreen (Glass), OPC, Stainless Steel, DC, User Manual on CD-ROM	7685ST-10C	
12.1" Color TFT Display, Touchscreen (Glass), OPC, Painted Steel, DC, User Manual on CD-ROM	7685T-12C	
12.1" Color TFT Display, Touchscreen (Glass), OPC, Stainless Steel, DC, User Manual on CD-ROM	7685ST-12C	
15.1" Color TFT Display, Touchscreen (Glass), OPC, Painted Steel, DC, User Manual on CD-ROM	7685T-15C	
15.1" Color TFT Display, Touchscreen (Glass), OPC, Stainless Steel, DC, User Manual on CD-ROM	7685ST-15C	
Blind Node (No Display, Table 48-22 for display options), OPC, DC, User Manual on CD-ROM	7600C	

Note: Customs available upon request.

ePro PS

Table 48-19. PanelMate ePro PS Spare Parts for all New RoHS Compliant Models ^①

Standard	Enterprise Edition	Classic	Outdoor	Description	Catalog Number	Price U.S. \$
8.4" Models						
✓	✓	✓		Color TFT Display Assembly Acrylic Touchscreen (gaskets 32-01682 and 32-02208 required)	35-4756-3 47-50888	
	✓	✓		Acrylic Touchscreen (gaskets 32-01682 and 32-02208 required)	47-50888-1	
✓	✓	✓	✓	Front Panel Assembly	91-01494	
✓	✓	✓	✓	Gasket for Front Panel	32-01682	
✓	✓	✓	✓	Gasket for Touchscreen	32-02208	
✓	✓	✓	✓	Backlight Kit	99-5704	
✓	✓	✓	✓	Ship Kit	86-00088	
			✓	Outdoor Color TFT Display Assembly	34-4290	
			✓	Outdoor Acrylic Touchscreen (gaskets 32-1682 and 32-02208 required)	47-50888-2	
10.4" Models						
✓	✓	✓		Color TFT Display Assembly	35-4756-2	
✓	✓	✓		Glass Touchscreen	63-00585	
✓	✓	✓		Front Panel (CRS) Assembly (gaskets 32-02545 and 32-02546 required)	32-02544	
✓	✓	✓		Front Panel (SST) Assembly (gaskets 32-02545 and 32-02546 required)	32-02550	
✓	✓	✓		Gasket for Front Panel	32-02545	
✓	✓	✓		Gasket for Touchscreen	32-02546	
✓	✓	✓		Backlight Kit	99-5704-2	
✓	✓	✓		Ship Kit	86-00090	
12.1" Models						
✓	✓	✓		Color TFT Display Assembly	35-4756	
✓	✓	✓		Glass Touchscreen	63-00808	
✓	✓	✓	✓	Front Panel (CRS) Assembly (gaskets 32-02491 and 32-02492 required)	32-02489	
✓	✓	✓	✓	Front Panel (SST) Assembly (gaskets 32-02491 and 32-02492 required)	32-02514	
✓	✓	✓	✓	Gasket for Front Panel	32-02491	
✓	✓	✓	✓	Gasket for Touchscreen	32-02492	
✓	✓	✓	✓	Backlight Kit	99-5704-3	
✓	✓	✓	✓	Ship Kit	86-00089	
			✓	Outdoor Color TFT Display Assembly	34-4289	
			✓	Outdoor Glass Touchscreen	63-00841	
15.0" Models						
✓	✓	✓		Color TFT Display Assembly	63-00814	
✓	✓	✓		Glass Touchscreen	63-00809	
✓	✓	✓	✓	Front Panel (CRS) Assembly (gaskets 32-02497 and 32-02498 required)	32-02490	
✓	✓	✓	✓	Front Panel (SST) Assembly (gaskets 32-02497 and 32-02498 required)	32-02515	
✓	✓	✓	✓	Gasket for Front Panel	32-02497	
✓	✓	✓	✓	Gasket for Touchscreen	32-02498	
✓	✓	✓	✓	Backlight Kit	87-02457	
✓	✓	✓	✓	Ship Kit	86-00089	
			✓	Outdoor Color TFT Display Assembly	63-00853	
			✓	Outdoor Glass Touchscreen	63-00850	
			✓	Outdoor Backlight Kit	87-02515	
Blind Node						
✓	✓	✓		Ship Kit	86-00087	

^① RoHS compliant units have a silver-colored galvanized steel back cover. Non-RoHS compliant units have a gold-colored plated steel back cover.

Table 48-20. PanelMate ePro PS Spare Parts for all Legacy Non-RoHS Compliant Models ①

Standard	Enterprise Edition	Classic	Outdoor	Description	Catalog Number	Price U.S. \$
8.4" Models						
✓	✓	✓		Color TFT Display Assembly	63-00544	
✓	✓	✓	✓	Acrylic Touchscreen (gaskets 32-01682 and 32-02208 required)	63-00833	
			✓	Front Panel Assembly	91-01494	
✓	✓	✓	✓	Gasket for Front Panel	32-01682	
✓	✓	✓	✓	Gasket for Touchscreen	32-02208	
✓	✓	✓	✓	Backlight Kit	87-02455	
✓	✓	✓	✓	Ship Kit	86-00088	
			✓	Outdoor Color TFT Display Assembly	63-00854	
			✓	Outdoor Acrylic Touchscreen (gaskets 32-1682 and 32-02208 required)	63-00848	
10.4" Models						
✓		✓		Color TFT Display Assembly	63-00852	
✓		✓		Glass Touchscreen	63-00585	
✓		✓		Front Panel (CRS) Assembly (gaskets 32-02545 and 32-02546 required)	32-02544	
✓		✓		Front Panel (SST) Assembly (gaskets 32-02545 and 32-02546 required)	32-02550	
✓		✓		Gasket for Front Panel	32-02545	
✓		✓		Gasket for Touchscreen	32-02546	
✓		✓		Backlight Kit	87-02514	
✓		✓		Ship Kit	86-00090	
12.1" Models						
✓	✓			Color TFT Display Assembly	63-00815	
✓	✓			Glass Touchscreen	63-00808	
✓	✓		✓	Front Panel (CRS) Assembly (gaskets 32-02491 and 32-02492 required)	32-02489	
✓	✓		✓	Front Panel (SST) Assembly (gaskets 32-02491 and 32-02492 required)	32-02514	
✓	✓		✓	Gasket for Front Panel	32-02491	
✓	✓		✓	Gasket for Touchscreen	32-02492	
✓	✓		✓	Backlight Kit	87-02456	
✓	✓		✓	Ship Kit	86-00089	
			✓	Outdoor Color TFT Display Assembly	63-00842	
			✓	Outdoor Glass Touchscreen	63-00841	
15.0" Models						
✓	✓			Color TFT Display Assembly	63-00814	
✓	✓			Glass Touchscreen	63-00809	
✓	✓		✓	Front Panel (CRS) Assembly (gaskets 32-02497 and 32-02498 required)	32-02490	
✓	✓		✓	Front Panel (SST) Assembly (gaskets 32-02497 and 32-02498 required)	32-02515	
✓	✓		✓	Gasket for Front Panel	32-02497	
✓	✓		✓	Gasket for Touchscreen	32-02498	
✓	✓		✓	Backlight Kit	87-02457	
✓	✓		✓	Ship Kit	86-00089	
			✓	Outdoor Color TFT Display Assembly	63-00853	
			✓	Outdoor Glass Touchscreen	63-00850	
			✓	Outdoor Backlight Kit	87-02515	
Blind Node						
✓	✓	✓		Ship Kit	86-00087	

① RoHS compliant units have a silver-colored galvanized steel back cover. Non-RoHS compliant units have a gold-colored plated steel back cover.

Stand-Alone Touchscreen Displays

PanelMate Stand-Alone
Touchscreen Displays

TFT Stand-Alone Touchscreen Display

Product Description

Three sizes of color TFT flat panel displays with touchscreens are available for use with the PanelMate ePro Blind Nodes. Models are available in 12.1, 15.0 and 17.0-inch sizes. These displays are constructed to handle rugged environments and can be easily mounted in a cabinet or a kiosk.

Features

- 12.1-inch SVGA, 15.0-inch XGA and 17.0-inch SXGA Color TFT LCD displays.
- 5-wire analog resistive ELO touchscreen.
- Stainless steel open-frame architecture.
- Aluminum front bezel.
- Strengthened glass protects the front panel from shock damage.
- Approved for use in Type 4, 12 and IP65 installations when properly mounted in a correspondingly rated enclosure.

Standards and Certifications

- CE
- FCC Class A
- UL

Technical Data

Table 48-21. PanelMate Stand-Alone Touchscreen Displays Technical Data

Description	Specification
Voltage	100 – 240V AC
System Ambient Operating Temperature	Operating: 32 – 122°F (0 – 50°C)
System Vibration	12.1" Models: 10 – 200 Hz, 0.15 mm, 10 cycle, 1G 15.0" Models: 10 Hz, 0.15 mm, 10 cycle, 1G 17.0" Models: 10 – 500 Hz
System Shock	12.1" Models: 15G peak acceleration (50 mS duration) 15.0" Models: 30G peak acceleration (11 mS duration) 17.0" Models: 30G peak acceleration (11 mS duration)
Backlight	12.1" Models: 50,000 typical life 15.0" Models: 50,000 typical life 17.0" Models: 30,000 typical life
Overall Dimensions (H x W x D)	12.1" Models: 11.46 x 14.41 x 1.92 in. (291.1 x 366.0 x 48.8 mm) 15.0" Models: 13.23 x 17.48 x 2.10 in. (336.0 x 444.0 x 53.3 mm) 17.0" Models: 15.71 x 19.02 x 2.25 in. (399.0 x 483.1 x 57.2 mm)
Cutout Dimensions (H x W)	12.1" Models: 10.16 x 13.11 in. (258.1 x 333.0 mm) 15.0" Models: 11.77 x 15.94 in. (299.0 x 404.9 mm) 17.0" Models: 14.45 x 17.68 in. (367.0 x 449.1 mm)
Weight	12.1" Models: 12 lbs. (5.5 kg) 15.0" Models: 14 lbs. (6.5 kg) 17.0" Models: 34 lbs. (15.4 kg)

Product Selection

Table 48-22. Stand-Alone Touchscreen Displays

Description	Catalog Number	Price U.S. \$
12.1" Color TFT Display, ELO Touchscreen (glass), AC	7585DT-12	
15.0" Color TFT Display, ELO Touchscreen (glass), AC	7585DT-15	
17.0" Color TFT Display, ELO Touchscreen (glass), AC	7585DT-17	

Canvas Editing Software

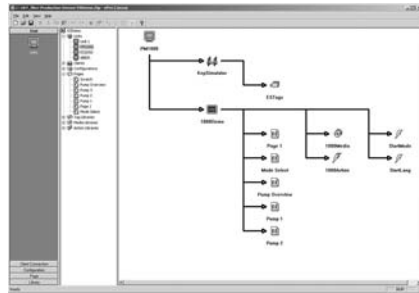

Canvas Editor

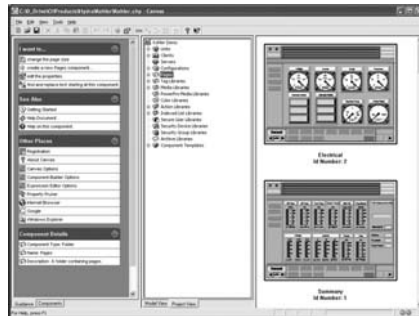

Canvas Editor with Page Thumbnails



Canvas Application

Product Description

The Canvas Software includes the Canvas application development software in addition to the Runtime software for the PanelMate ePro PS and the OPC servers/drivers. Canvas software is used to develop Operator Interface applications for PanelMate ePro PS industrial Operator Interface products. The powerful editing environment in Canvas delivers state-of-the-art features previously available only on more expensive, high-end SCADA packages. The included drivers in the form of OPC servers support Ethernet and serial connectivity to virtually any PLC platform or network, as well as a wide array of drives, motion controllers and databases. No additional fees are required.

Because the typical application development expense of a Human Machine Interface (HMI) often far outweighs the expense of the hardware, the demand to design and implement these advanced solutions quickly is of paramount importance. That is why the Canvas advanced Operator Interface software package was designed with ease of use and time savings in mind.

Consistent functionality in Canvas from one control to the next and from one area to the next will help you maintain your sense of place within the project and shorten the development time. Canvas makes it easy to create and maintain an application with advanced features such as multi-language, security, recipe management and data archiving. Data may be exported, edited and imported with Microsoft Excel, saving time and ultimately reducing the cost of the project.

Features

- Operator Interface — Monitor and Control
- High-Resolution Graphical Interface
- Built-in Two-touch Control for Safety Applications
- Process/Machine Diagnostics
- Conversion of Legacy PanelMate Configurations
- Secure Document and Web/Network Browser
- Full Mathematical Evaluation

- Advanced Search and Replace
- Security (Passwords and other Security Devices)
- Recipe Management
- Real-time and Historical Alarms and Events
- Real-time and Historical Data Archiving and Trending
- Notification of Data and Events via E-mail
- Import/Export from XML
- Customizable Templates/Controls
- Scripting (IF, THEN, ELSE, GOTO capability)
- Launch and Control of 3rd-Party Applications
- Multi-Language
- Reusable Controls, Images and Pages via Index Lists
- Master Pages
- Online and Offline Simulation
- Interface for DVT & Cognex Vision Systems

Hardware Requirements

System Requirements for Running Canvas Software ①

- Operating system — Microsoft® Windows XP (SP1 or later) or Microsoft® Windows Vista (Canvas V3.3 or later)
- Minimum Video Resolution — XGA (1024 x 768)

① File transfers can be done via Ethernet or USB memory devices.

Product Selection

Table 48-23. Canvas

Description	Catalog Number	Price U.S. \$
Includes Canvas software for developing applications, Runtime software for the PanelMate ePro PS Series and supporting OPC servers/drivers. Single User License. On CD-ROM. Development software requires Windows 2000 or Windows XP Operating System.	CANVASPRO	
Site License — See CANVASPRO (for all users at 1 site location)	CANVASPROSL	
Installation CD and licensing to run Canvas runtime software on a PC with Windows XP Professional OS. Licenses for Kepware OPC servers, Data Archiving and Recipe Management are included.	CANVASPC	

Discount Symbol **PM-1**

PanelMate Power Pro Overview



PanelMate Power Pro

Product Description

The PanelMate Power Pro Operator Interfaces are a cost-efficient, easy-to-integrate alternative to traditional hardwired operator panels in control systems. The PanelMate Power Pro products pack the latest advanced-technology operator interface functionality into a unique, versatile line of flatpanel designs.

The PanelMate Power Pro products have the same cutout and stud pattern as earlier model PanelMate products and offer increased capabilities.

Control functions, such as machine status indication and pushbutton-style control, are accomplished using built-in templates displayed on a vivid screen. The PanelMate Power Pro simulates the action and performance of hardwired pushbuttons using sealed, recessed membrane control buttons on the touchpanel version or on-screen buttons on the touchscreen version. The proven intuitive operation remains the same in all PanelMate products.

Operators select templates or graphic images by moving a finger around the touchpanel or touchscreen. After selecting a template, the operator performs control actions by pressing control buttons. New functionality also allows users to navigate and initiate control action with just one touch (touchscreen only), if such functionality is configured for the unit using the PanelMate Power Pro Windows-based configuration software.

Simplified Machine Control

- Higher level functions such as machine setup, diagnostics, alarming, trending and custom graphics can be configured easily using the PanelMate Power Pro configuration software. This intuitive software significantly reduces the time and effort needed to create your application. The software also provides complete compatibility of configuration files with other PanelMate series products (Version 2.1 or later).
- Realistic representations of machines and processes can be displayed on all PanelMate models. Detailed symbols can be designed to the pixel level or selected from a symbol library of over 3000 customizable and scalable images. These graphics make displays more meaningful and allow operators to easily recognize and understand the displayed data. The eight-state blinking feature can be used to highlight critical functions, provide animation effects and attract the operator's attention to important information.
- Application flexibility is provided by hardware features that include:
 - Approved for use in Type 4, 4X and 12 installations when properly mounted in a correspondingly rated enclosure. Stainless steel models available for PanelMate Power Pro 3000 and 5000 series.
 - Executive firmware stored in non-volatile flash memory for easy upgrades.
 - Battery-backed clock that can be synchronized externally.
 - Two RS-232/RS-422 serial ports for communications or printing alarms and messages (except PM 1100 models).
 - Optional, high-speed, network interface boards for connectivity to a variety of networks.
 - System diagnostics.
 - All PanelMate Power Pro systems meet UL®, CSA®, CE requirements and UL/CSA Class I Division 2 Groups A, B, C, D requirements.
 - All PanelMate Power Pro models have up to 100-page, 5000-message capacity.
 - PanelMate Pro LT supports up to 64 I/O references (expandable up to 512 I/O points) and a single communication driver.

- Display features on all units provide VGA (640 x 480) resolution with:
 - 256-level grayscale on the grayscale versions or 256-color palette on color versions.
- Touchpanel for all models include a display with electronics module and membrane keypad with off-screen 3 x 5 cell control selection, cancel key and numeric entry keypad, with four redefinable membrane control buttons to the right of the display. The PanelMate 5000 units have five membrane control buttons.
- Touchscreen for all models include a display with electronics module and on-screen 3 x 5 cell control selection, four redefinable on-screen control buttons, on-screen cancel key and non-intrusive, pop-up, on-screen numeric keypad. The PanelMate 5000 units have five on-screen control buttons.

Displays Available

- 7.4-inch grayscale LCD Flatpanel (PM Pro LT 1100, PMPP 1700).
- 7.7-inch color DSTN Flatpanel (PM Pro LT 1100, PMPP 1700).
- 8.4-inch color TFT Flatpanel (PMPP 1700).
- 10.4-inch color TFT Flatpanel (PMPP 3000 and 5000).
- Split Architecture 10.4-inch color TFT Flatpanel (PMPP 5000).
- All models available in touchscreen and touchpanel (keypad).

PanelMate Pro LT 1100

Product Description

The PanelMate Pro LT 1100 is available with a 7.4-inch grayscale LCD or 7.7-inch color Dual Scan (DSTN) display with full VGA resolution and 256 shades/colors. Models are available with either touchscreen (acrylic) or touchpanel for operator input and can be mounted in a 4-inch deep enclosure. The PanelMate Pro LT 1100 supports applications with up to 64 I/O references and a single communication driver. The number of supported I/O references can be upgraded to 512 I/O points (done in blocks of 64 I/O points — see 1100TAG Options). The PanelMate Pro LT 1100 requires 24V DC power input.

Product Selection

Table 48-24. PanelMate Pro LT 1100 Operator Stations ①

Description	Catalog Number	Price U.S. \$
7.4" Grayscale LCD Display Touchpanel Touchscreen	1155K 1155T	
7.7" Color DSTN Display Touchpanel Touchscreen	1175K 1175T	

① Discount Symbol **PM-2**.

Table 48-25. PanelMate Pro LT 1100 Spare Parts

Description	Catalog Number	Price U.S. \$
7.4" Grayscale LCD Display Assembly for 1155 7.7" Color DSTN Display Assembly for 1175	63-00494 63-00678	
Keypad (4- & 15-position combined with window) for 1155K, 1175K (gasket 32-01941 required)	63-00742	
Gasket for Keypad (between keypad and display) for 1155K, 1175K	32-01941	
Touchscreen for 1155T and 1175T (gaskets 32-01682 and 32-01941 required) Do not replace 63-00632, contact factory	63-00838	
Gasket for Touchscreen for 1155T, 1175T: Between touchscreen and front panel Between touchscreen and display	32-01682 32-01941	
Front Panel Assembly for 1155K, 1175K Front Panel Assembly for 1155T, 1175T	91-01913 91-01494	
Backlight Kit for 1155 Backlight Kit for 1175	87-02144 ②	
Ship Kit for 1155K, 1175K Ship Kit for 1155T, 1175T	86-00078 86-00077	

② Contact factory.

PanelMate Power Pro 1700

Product Description

The PanelMate Power Pro 1700 is available with a 7.4-inch grayscale LCD, 7.7-inch color Dual-Scan (DSTN) or 8.4-inch color TFT display with full VGA resolution and 256 shades/colors. Models are available with either touchscreen (acrylic) or touchpanel for operator input and can be mounted in a 4-inch deep enclosure. The PanelMate Power Pro models require 24V DC power input.

Product Selection

Table 48-26. PanelMate Power Pro 1700 Operator Stations

Description	Catalog Number ③	Price U.S. \$
7.4" Grayscale LCD Display Touchpanel Touchscreen	1755K 1755T	
7.7" Color DSTN Display Touchpanel Touchscreen	1775K 1775T	
8.4" Color TFT Display Touchpanel Touchscreen	1785K 1785T	

③ Add "**-CC**" after the Catalog Number for conformal coating. Example: 1755K-CC.

Table 48-27. PanelMate Power Pro 1700 Spare Parts

Description	Catalog Number	Price U.S. \$
7.4" Grayscale LCD Display Assembly for 1755 7.7" Color DSTN Display Assembly for 1775 (units with PN greater than 92-01902) 8.4" Color TFT Display Assembly for 1785	63-00494 63-00678 63-00544	
Keypad (4- & 15-position combined with window) for 1755K, 1775K (gasket 32-01941 required)	63-00742	
Gasket for Keypad (between keypad and display) for 1755K, 1775K Front Panel Gasket for 1755K, 1775K	32-01941 32-02229	
Keypad (4- & 15-position combined with window) for 1785K (gasket 32-02208 required)	63-00741	
Gasket for Keypad (between keypad and display) for 1785K	32-02208	
Touchscreen for 1755T, 1775T (gaskets 32-01682 and 32-01941 required) Do not replace 63-00632; contact factory	63-00835	
Gasket for Touchscreen for 1755T, 1775T: Between touchscreen and front panel Between touchscreen and display	32-01682 32-01941	
Touchscreen for 1785T (gaskets 32-01682 and 32-02208 required)	63-00831	
Gasket for Touchscreen for 1785T: Between touchscreen and front panel Between touchscreen and display	32-01682 32-02208	
Front Panel Assembly for 1755K, 1775K Front Panel Assembly for 1785K Front Panel Assembly for 1755T, 1775T, 1785T	91-01801 91-01826 91-01494	
Gasket for Mounting 1785T Front Panel Assembly	32-02005	
Backlight Kit for 1755 Backlight Kit for 1775 Backlight Kit for 1785	87-02144 ① 87-02455	
Ship Kit for 1755K, 1775K, 1785K Ship Kit for 1755T, 1775T, 1785T	86-00060 86-00059	

① Contact factory.

PanelMate Power Pro 3000

Product Description

The PanelMate Power Pro 3000 is available with a 10.4-inch color TFT display with full VGA resolution and 256 colors. Models are available with either touchscreen (glass or acrylic) or touchpanel for operator input and with painted steel or stainless steel front panels. These units can be mounted in a 5-inch deep enclosure. The PanelMate Power Pro models require 24V DC power input.

Product Selection

Table 48-28. PanelMate Power Pro 3000 Operator Stations

Description	Catalog Number ^①	Price U.S. \$
10.4-Inch Color TFT Display		
Touchpanel Painted Steel	3985K	
Touchpanel Stainless Steel	3985SK	
Touchscreen (glass) Painted Steel	3985T	
Touchscreen (glass) Stainless Steel	3985ST	
Touchscreen (acrylic) Painted Steel	3985AT	
Touchscreen (acrylic) Stainless Steel	3985SAT	

① Add “-CC” after the Catalog Number for conformal coating.
Example: 3985K-CC.

Table 48-29. PanelMate Power Pro 3000 Spare Parts

Description	Catalog Number	Price U.S. \$
10.4" Color TFT Display Assembly for 3985	63-00778	
Keypad (4- & 15-position combined with window) for 3985K	63-00740	
Plexi-Glass Window for 3985K Series	32-02151	
Touchscreen (glass) for 3985T and 3985ST	63-00585	
Touchscreen (acrylic) for 3985AT and 3985SAT	63-00592	
Front Panel for 3985K (gasket 32-02143 required)	32-02141	
Front Panel for 3985SK (gasket 32-02143 required)	32-02288	
Gasket for Front Panel for 3985K and 3985SK	32-02143	
Front Panel for 3985T and 3985AT (gaskets 32-02144 and 32-02145 required)	32-02142	
Front Panel for 3985ST and 3985SAT (gaskets 32-02144 and 32-02145 required)	32-02289	
Gasket for Front Panel for 3985T, 3985ST, 3985AT and 3985SAT	32-02144	
Gasket for Touchscreen for 3985T, 3985ST, 3985AT and 3985SAT	32-02145	
Backlight Kit for 3985	87-02379	
Ship Kit for 3985	86-00066	

PanelMate Power Pro 5000

Product Description

The PanelMate Power Pro 5000 features a large, easy-to-see 10.4-inch color TFT display with full VGA resolution and 256 colors. Models are available with a touchscreen (glass) or touchpanel for operator input and with painted steel or stainless steel. The touchpanel versions are available with either of two designs — single-piece front panel or the split architecture design. The touchpanel models can be mounted in a 19-inch rack. The cutout and stud patterns for all models are the same as earlier versions of PanelMate products that featured the 13-inch display, including the PanelMate I/II/III. The PanelMate Power Pro models require 24V DC power input. The PanelMate Power Pro 5000 can also be ordered with an ac power converter mounted on the back.

Product Selection

Table 48-30. PanelMate Power Pro 5000 Operator Stations

Description	Catalog Number ^②	Price U.S. \$
10.4" Color TFT, Single Piece Front Panel		
Touchpanel Painted Steel	5785K	
Touchpanel Stainless Steel	5785SK	
Touchpanel Painted with ac Power Converter	5785K-AC	
Touchscreen Painted Steel	5785T	
Touchpanel Stainless Steel	5785ST	
Touchscreen Painted with ac Power Converter	5785T-AC	
10.4" Color TFT, Split Architecture Design		
Touchpanel Painted Steel	5485K	
Touchpanel Stainless Steel	5485SK	
Touchpanel Painted with ac Power Converter	5485K-AC	

② Add “-CC” after the Catalog Number for conformal coating.
Example: 5785K-CC.

Table 48-31. PanelMate Power Pro 5000 Spare Parts

Description	Catalog Number	Price U.S. \$
10.4" Color TFT Display Assembly for 5485, 5785 10.4" Backlight Kit for 5485, 5785 10.4" Front Panel for 5585K, 5785K (gasket 32-02301 and 32-02145 required)	63-00778 87-02379 47-50632	
10.4" Front Panel (SST) for 5585SK, 5785SK (gasket 32-02301 and 32-02145 required) 10.4" Front Panel for 55885T, 5785T (gaskets 32-02204 and 32-02145 required) 10.4" Front Panel (SST) for 5585ST, 5785ST (gaskets 32-02204 and 32-02145 required)	47-50632-2 47-51017 47-51017-2	
10.4" Front Panel (Upper) for 5285K, 5485K (gasket 32-02308 and 32-02145 required) 10.4" Front Panel (Upper, SST) for 5285SK, 5485SK (gasket 32-02308 and 32-02145 required) 10.4" Gasket for Front Panel for 5585K, 5585SK, 5785K, 5785SK 10.4" Gasket for Front Panel 10.4" Touchscreen Glass for 5585T, 5785T	47-51016 47-51016-2 32-02301 32-02145 63-00585	
13.0" Touchscreen for 5585T, 5785T 13.0" Front Panel for 5585K, 5785K (gasket 32-02301 required) 13.0" Front Panel (SST) for 5585SK, 5785SK (gasket 32-02301 required)	63-00658 32-02206 32-02432	
13.0" Front Panel for 55885T, 5785T (gaskets 32-02204 and 32-02066 required) 13.0" Front Panel (SST) for 5585ST, 5785ST (gaskets 32-02204 and 32-02066 required) 13.0" Front Panel (Upper) for 5285K, 5485K (gasket 32-02308 required)	32-02200 32-02430 32-02297	
13.0" Front Panel (Upper, SST) for 5285SK, 5485SK (gasket 32-02308 required) 13.0" Gasket for Front Panel for 5585K, 5585SK, 5785K, 5785SK 13.0" Gasket for Touchscreen for 5585T, 5585ST	32-02433 32-02301 32-02066	
Gasket for Front Panel for 5585T, 5585ST Gasket for Upper Front Panel for 5285K, 5285SK, 5485K, 5485SK	32-02204 32-02308	
Membrane Keypad (5- & 15-position combined) for 5585K, 5785K Membrane Keypad (5-position) for 5285K, 5485K Membrane Keypad (15-position) for 5285K, 5485K	63-00714 63-00715 63-00375	
Front Panel (Lower) for 5285K, 5485K (gasket 32-01392 required) Front Panel (Lower, SST) for 5285SK, 5485SK (gasket 32-01392 required)	32-02303 32-01388	
Gasket for Lower Front Panel for 5285K, 5285SK, 5485K, 5485SK	32-01392	
Backlight Kit for 5585, 5285	87-02137	
Add-On 115/230V AC to 24V DC Power Converter for PanelMate Power Pro 5000, all models Mounts on back of unit and adds 1.5" of depth	PM5000-ACKIT	
Ship Kit for 5585K, 5785K Ship Kit for 5585T, 5785T Ship Kit for 5285K, 5485K	86-00067 86-00068 86-00069	

PC Pro Runtime Hardware Key

PanelMate PC Pro Runtime Hardware Key

Product Description

PanelMate PC Pro is an online version of the PanelMate Power Pro executive software and communication drivers, designed to run on an industry-standard Intel-based personal computer and the Windows NT 4.0 operating system. PanelMate PC Pro is a full 32-bit, Windows NT-compliant software package with 32-bit Windows NT PLC drivers, created to take advantage of standard, open architecture hardware and software developed by other vendors, while maintaining the PanelMate's legendary simplicity and ease of use.

PanelMate PC Pro System Requirements

PanelMate PC Pro software can be installed on any PC running Windows NT 4.0 or greater which meets the following minimum requirements:

- Intel Pentium 133 MHz (200 MHz recommended).
- 32 MB DRAM (64 MB recommended).
- 1 GB hard drive.
- VGA controller and monitor.
- Pointing device (touchscreen preferred).
- Windows NT Workstation V 4.0.

Benefits

- PanelMate PC Pro allows the user to tap into the valuable data in PanelMate from other PC applications because PanelMate PC Pro is open — Bring data from the plant level down to PanelMate, or feed data from PanelMate PC Pro to other information systems in the plant.
- PanelMate PC Pro adheres to Windows standards and is 100% Windows compatible, allowing you to use the extensive networking capabilities of Windows NT.

- Use of an open hardware/software platform allows the customer to precisely meet their ever-changing needs with easy processor or capacity upgrades, using off-the-shelf hardware. Supplemental functionality can be added using off-the-shelf software, allowing the user to incorporate control, operator interface, analysis, reporting, communications, etc., into one workstation.
- Use an efficient, Dynamic Link Library (DLL) interface to connect the tried-and-true PanelMate operator interface with Steeplechase's popular Visual Logic Controller soft logic PC control package.
- PanelMate PC Pro has the same functionality as the PanelMate Power Pro and is fully compatible with applications created for PanelMate Power Series/PanelMate Power Pro products. Any Power Series/Power Pro application will run on PanelMate PC Pro.

Note: When purchasing a PanelMate ePro PS Classic Operator Interface, PanelMate PC Pro is already integrated and ready to run.

Product Selection

Table 48-32. PanelMate PC Pro Runtime Hardware Key and License

Description	Catalog Number	Price U.S. \$
Runtime Hardware Key to Enable PanelMate PC Pro Runtime Software Key connects to the PC parallel port and has pass-through capabilities. The hardware key is required for PanelMate online operation.	PMPC-RT	

Note: Runtime software is included with PanelMate Configuration Software #PMPROSW and #PMPROSWSL, see **Page 48-31**.

Power Pro Software

PanelMate Power Pro and PanelMate PC Pro Configuration Software

Application Description

Windows-based configuration software is used to create PanelMate Power Pro, PanelMate PC Pro and PanelMate ePro configurations offline on a PC. It also permits the editing of character-based configurations from earlier-version PanelMate Series products. The following items can be configured:

- One-touch control (for touchscreen models).
- Customizable pixel-level graphics.
- 8-state blink (for 256-level/color models).
- 3-level password protection.
- International character set support.
- Page change by operators and/or PLC.
- User-definable online system prompts to permit non-English or customized text that can be toggled with standard online prompts by operators.
- Alarm window with a 100-alarm capacity.

Features

- Indicator templates.
- Readout templates.
- Bar templates.
- Display templates.
- Trend templates.
- Table templates.
- Variable-size control button templates.
- Pop-up maintenance window.
- Alarm window.
- Advanced trend templates.
- Tag name file support.
- Expression management.
- 3000 symbol factory clipart.

PLC Communication Interfaces

Communication interfaces are available for the following programmable controllers and are downloaded from the configuration software.

Note: Multiple interfaces may be run simultaneously on PanelMate Power Pro 1700, 2000, 3000, 4000 and 5000 units.

- Allen-Bradley PLC-2, PLC-3, PLC-5 and SLC-500.
- Cutler-Hammer D50, D300, D320.
- GE® Fanuc® Series 5, 6, 90.
- Mitsubishi® "A" Series and "FX" Series.
- Modicon® Modbus® ASCII/RTU.
- Omron "C" Series plus CV500, CV1000.
- PLC-Direct DL 405 Family.
- Square D® SyMax.

- Siemens® S5 Series, 3964R Protocol, AS511.
- Simatic® TI 305/405 and 500/505 Series.
- Reliance AutoMate®.
- Toshiba T2.

High Speed Direct Connectivity Available

- Allen-Bradley Data Highway and Data Highway Plus.
- Allen-Bradley Remote I/O Link.
- GE Fanuc Genius® I/O Network.
- DeviceNet™.
- Modicon Modbus Plus.
- PROFIBUS®.

Transfer Cables

PanelMate configuration software packages #PMPROSW and #PMPROSWSL include a PanelMate 1100, 1700, 3000, 5000 (#0518) Transfer Serial Cable.

Product Selection

Table 48-33. Windows Configuration Software for PanelMate Power Pro and PanelMate PC Pro

Description	Catalog Number	Price U.S. \$
PanelMate Power Pro Windows Configuration Software and Manuals with Communication Software Interfaces for all major PLCs and High-Speed Industrial Networks on CD-ROM with Tag and Expression Management and Symbol Factory Clipart. #PMPROSW includes transfer serial cable for PM1700, 3000, 5000 (#0518). #PMPROSW includes electronic copies of manuals in .PDF format. Single User License.	PMPROSW	
Site License — See PMPROSW (for all users at 1 site location)	PMPROSWSL	
PanelMate Power Pro Upgrade from previous PanelMate Power Series Software to PanelMate Power Pro software version on CD-ROM. Requires earlier version of PanelMate Power Series software for installation. Single User License.	PMPROSWUP	
PanelMate Power Pro Software Upgrade — Site License Requires previous installation of PanelMate Power Pro Software Site License (PMPROSWSL). On CD-ROM.	PMPROSWSLUP	

Allen-Bradley Connectivity

Remote I/O, Data Highway, Data Highway Plus

Accelerate/On Interface

Licensed under A-B patented technology, the interface provides a communication port for connecting directly to the user's choice of Allen-Bradley PLC networks: Remote I/O Link, Data Highway® or Data Highway Plus. Can be used simultaneously with PanelMate 1700, 3000 and 5000 serial ports.

Table 48-34. Remote I/O, Data Highway, Data Highway Plus

Description	Catalog Number	Price U.S. \$
Accelerate/On™ Interface Direct connect to Remote I/O Link, Data Highway or Data Highway Plus PanelMate Power Pro 1100, 1700 PanelMate Power Pro 3000, 5000	1241 1251	

Note: Includes royalty for license under Allen-Bradley patented technology.

Allen-Bradley PLC Network Upload/Download

"One-time use" diskette enables the PanelMate unit to upload and download PanelMate configurations to PCs via Allen-Bradley PLC networks. This Upload/Download feature can be used to conduct the following operations without having to disconnect the PanelMate Unit from the PLC, or open the enclosure to access the serial ports:

- Download configurations from a PC in a central location to PanelMate units on a network.
- Upload PanelMate configurations (while units are monitoring and controlling) to a PC for backup.
- Download new PanelMate software enhancements to units.

Note: Requires Accelerate/On Interface (#XX41) and Windows Configuration Software or Transfer Utility option #0621.

- Requires A-B RSLinx-OEM version 2.0 or higher or A-B Interchange software.

Table 48-35. Allen-Bradley PLC Network Upload/Download

Description	Catalog Number	Price U.S. \$
One-time use diskette. Enables upload/download on operator station.	0524	

Allen-Bradley DH-485 (SLC-500) Communications

"One-time use" diskette. Licensed under A-B patented technology, this option enables communications to Allen-Bradley SLC-500 PLCs through the DH-485 network in a single target Power Series online unit. A-B 1747-AIC Module is only required when simultaneous interface to PanelMate and PLC programming equipment is desired.

Table 48-36. DH-485

Description	Catalog Number	Price U.S. \$
Allen-Bradley DH-485 (SLC-500) Communications — One-time use diskette PanelMate Power Pro 1100, 1700 PanelMate Power Pro 3000, 5000	1525 0725	

Note: Includes royalty for license under Allen-Bradley patented technology.

Allen-Bradley Communication Cables

PLC Interface Cables for PanelMate Power Pro 1100, 1700, 3000, 5000 and ePro

One 15-foot (4.6 m) cable, unless otherwise stated, for communications between a PanelMate 1100, 1700, 3000, 5000 or ePro unit serial port and the PLC communications port using D-Shell connectors. Cables used with PanelMate ePro require a DB9(M)/DB9(F) converter [converts DB9(M) to DB9(F)].

Table 48-37. PLC Interface Cables for PanelMate Power Pro 1100, 1700, 3000, 5000 and ePro

Description	Catalog Number	Price U.S. \$
1785-KE, 1771-KC, KD, KE, KF, KG AB 1747 AIC for SLC 500 (DH-485 INTFC)	AB21 AB23A	
AB SLC 500 Direct (6 ft./1.8 m) Cable AB SLC503/504 (RS-232) Channel 0 AB PLC5 (RS-232) Channel 0, DF1	AB24A AB25 AB26	
AB PLC5 (RS-422) Channel 0, DF1 Cable AB 1747 AIC for SLC 500, CPU Connector (J1) AB MicroLogix™ Adapter Cable (1 ft./3 m) (DB9F to DB9M)	AB27A AB28A AB29	

Eaton's Cutler-Hammer Connectivity

Cutler-Hammer Communication Cables

PLC Interface Cables for PanelMate Power Pro 1100, 1700, 3000, 5000, ePro

One 15-foot (4.6 m) cable, unless otherwise stated, for communications between a PanelMate 1100, 1700, 3000, 5000 or ePro unit serial port and the PLC communications port using D-Shell connectors.

Table 48-38. PLC Interface Cables for PanelMate Power Pro 1100, 1700, 3000, 5000, ePro

Description	Catalog Number	Price U.S. \$
Cutler-Hammer D200 Cable, for use with 1100, 1700, 3000 or 5000 only	CH21A	
Cutler-Hammer D50/D150/D300/D320 (RS-485) Cable, for use with 1100, 1700, 3000 or 5000 only	CH22A	
Cutler-Hammer D50/D320/D32LT (RS-232) Cable for use with ePro and PMPC-RT only — requires D50CPM485	CH23	
ELC (RS-485) Cable for use with ePro PS and Power Pro only	CH24	

DeviceNet Connectivity

The PanelMate DeviceNet implementation features the ability to “monitor” status from other slave devices without the need for active involvement from the master device. When installed on DeviceNet, PanelMate can update its screens with data from the slave devices or from the PC. It can also input control (pushbutton) operations or numeric information to the PC. These capabilities permit PanelMate units to function as complete control and monitoring stations on DeviceNet.

Table 48-39. DeviceNet Interface

Description	Catalog Number	Price U.S. \$
For all PanelMate Power Pro 1100, 1700, 3000, 5000	1245DN	

General Electric Connectivity

GE Fanuc GENius I/O Interface to GE PLCs

This interface provides a communication port for connection to GE Series 6 and Series 90 PLCs over the GENius I/O Network.

Table 48-40. GENius I/O Interface

Description	Catalog Number	Price U.S. \$
GENius I/O Interface For all PanelMate Power Pro 1100, 1700, 3000, 5000	1243	

General Electric Communication Cables

PLC Interface Cables for PanelMate Power Pro 1100, 1700, 3000, 5000 or e-Pro

One 15-foot (4.6 m) cable, unless otherwise stated, for communications between a PanelMate 1100, 1700, 3000, 5000 or ePro unit serial port and the PLC communications port using D-Shell connectors. Cables used with PanelMate ePro require a DB9(M)/DB9(F) converter (converts DB9(M) to DB9(F)).

Table 48-41. PLC Interface Cables for PanelMate Power Pro 1100, 1700, 3000, 5000 or ePro

Description	Catalog Number	Price U.S. \$
Series 90 Programming Port Series 90 (RS-422) Com 311/711 Module Series 90 (RS-232) Com 311/711 Module	GE21A GE22 GE23	
Series 6/6+ (RS-422) Com 2 – J1 Port Series 6/6+ (RS-232) Com 2 – J2 Port	GE24 GE25	

Mitsubishi Connectivity

Mitsubishi Communication Cables

PLC Interface Cables for PanelMate Power Pro 1100, 1700, 3000, 5000 or ePro

One 15-foot (4.6 m) cable, unless otherwise stated, for communications between a PanelMate 1100, 1700, 3000, 5000 or ePro unit serial port and the PLC communications port using D-Shell connectors. Cables used with PanelMate ePro require a DB9(M)/DB9(F) converter (converts DB9(M) to DB9(F)).

Table 48-42. PLC Interface Cables for PanelMate Power Pro 1100, 1700, 3000, 5000 or ePro

Description	Catalog Number	Price U.S. \$
A Series — AJ71C24 Module (RS-232) A Series — AJ71C24 Module (RS-422) Cable FX/FXo Series — (RS-232/RS-422) Converter	MI21 MI22A MI23	

Modicon Connectivity

Modicon Modbus Plus PLC Network Upload/Download

“One-time use” diskette enables the PanelMate unit to upload and download PanelMate configurations to PCs via Modicon Modbus Plus PLC networks. This Upload/Download feature can be used to conduct the following operations without having to disconnect the PanelMate Unit from the PLC, or open the enclosure to access the serial ports:

- Download configurations from a PC in a central location to PanelMate units on a network.
- Upload PanelMate configurations (while units are monitoring and controlling) to a PC for backup.
- Download new PanelMate software enhancements to units.

Note: Requires Modbus Plus Interface, Configuration Software or Transfer Utility.

Table 48-43. Modicon Modbus Plus Network Upload/Download

Description	Catalog Number	Price U.S. \$
One-time use diskette. Enables upload/download on operator station. To operate, customer requires: 1) Modbus Plus Interface (1248) to be installed in unit 2) Windows Configuration Software OR Transfer Utility on the PC	0548	

Modbus Plus Communications and PanelMate

This interface provides a communication port for connection to Modicon PLCs over the Modbus Plus network. Interface mounts to the back of the online unit and can be mounted in a 4-inch (102 mm) deep enclosure.

Table 48-44. Modbus Interface

Description	Catalog Number	Price U.S. \$
Direct Modbus Plus Interface PanelMate Power Pro 1100, 1700, 3000, 5000	1248	

Modicon Communication Cables

PLC Interface Cables for PanelMate Power Pro 1100, 1700, 3000, 5000 or ePro

One 15-foot (4.6 m) cable, unless otherwise stated, for communications between a PanelMate 1100, 1700, 3000, 5000 or ePro unit serial port and the PLC communications port using D-Shell connectors. Cables used with PanelMate ePro require a DB9(M)/DB9(F) converter (converts DB9(M) to DB9(F)).

Table 48-45. PLC Interface Cables for PanelMate Power Pro 1100, 1700, 3000, 5000 or ePro

Description	Catalog Number	Price U.S. \$
9-Pin Modbus Micro PLC (RJ-45) Modbus Cable	MB21 MB22	

Omron Connectivity

Omron Communication Cables

PLC Interface Cables for PanelMate Power Pro 1100, 1700, 3000, 5000 or ePro

One 15-foot (4.6 m) cable, unless otherwise stated, for communications between a PanelMate1100, 1700, 3000, 5000 or ePro unit serial port and the PLC communications port using D-Shell connectors. Cables used with PanelMate ePro require a DB9(M)/DB9(F) converter (converts DB9(M) to DB9(F)).

Table 48-46. PLC Interface Cables for PanelMate Power Pro 1100, 1700, 3000, 5000 or ePro

Description	Catalog Number	Price U.S. \$
C Series (RS-232) CV Series (RS-232)	OM21 OM22	
C Series (RS-422) Cable CV Series (RS-422) Cable	OM23A OM24A	
CS/CQ Series (RS-232) Cable	OM25	

PROFIBUS DP Connectivity

PROFIBUS DP Interface

This PROFIBUS DP Slave Adapter interface provides communications between a PanelMate operator interface and a PROFIBUS network without requiring any additional communications modules. A maximum of one interface can be installed on each PanelMate unit.

Table 48-47. PROFIBUS DP Interface

Description	Catalog Number	Price U.S. \$
PROFIBUS DP Slave I/O Interface For all PanelMate Power Pro 1100, 1700, 3000, 5000	1247	

Siemens Connectivity

PLC Interface Cables for PanelMate Power Pro 1100, 1700, 3000, 5000 or ePro

One 15-foot (4.6 m) cable, unless otherwise stated, for communications between a PanelMate 1100, 1700, 3000, 5000 or ePro unit serial port and the PLC communications port using D-Shell connectors. Cables used with PanelMate ePro require a DB9(M)/DB9(F) converter (converts DB9(M) to DB9(F)).

Table 48-48. PLC Interface Cables for PanelMate Power Pro 1100, 1700, 3000, 5000 or ePro

Description	Catalog Number	Price U.S. \$
Siemens (RS-232) Siemens S7 HMi Cable	SI21 SI22	

Simatic TI Connectivity

Simatic TI Communication Cables

PLC Interface Cables for PanelMate Power Pro 1100, 1700, 3000, 5000 or ePro

One 15-foot (4.6 m) cable, unless otherwise stated, for communications between a PanelMate 1100, 1700, 3000, 5000 or ePro unit serial port and the PLC communications port using D-Shell connectors. Cables used with PanelMate ePro require a DB9(M)/DB9(F) converter (converts DB9(M) to DB9(F)).

Table 48-49. PLC Interface Cables for PanelMate Power Pro 1100, 1700, 3000, 5000 or ePro

Description	Catalog Number	Price U.S. \$
TI 500, 305 (RS-232) TI 405 (RS-232) TI 545 (RS-232)	TI21 TI22 TI23	
TI 305-02DM, TI 405 DCM (RS-422) Cable TI 545-1101 (RS-422) Cable TI 545-12102, 1104, 1105 Cable	TI25A TI26A TI27A	

Square D Connectivity

Square D Communication Cables

PLC Interface Cables for PanelMate Power Pro 1100, 1700, 3000, 5000 or ePro

One 15-foot (4.6 m) cable, unless otherwise stated, for communications between a PanelMate 1100, 1700, 3000, 5000 or ePro unit serial port and the PLC communications port using D-Shell connectors. Cables used with PanelMate ePro require a DB9(M)/DB9(F) converter (converts DB9(M) to DB9(F)).

Table 48-50. PLC Interface Cables for PanelMate Power Pro 1100, 1700, 3000, 5000 or ePro

Description	Catalog Number	Price U.S. \$
PLC Processor Cable NIM Network Interface Module Cable	SD21A SD22A	

Accessories

Transfer Serial Cable

One 15-foot (4.6 m), RS-232 cable with DB9 connectors on each end, for upload/download between standard serial PC communication port and PanelMate serial port.

Table 48-51. Transfer Serial Cable

Description	Catalog Number	Price U.S. \$
PanelMate 1100, 1700, 3000, 5000 Additional ①	0518	

① Included in configuration software package #PMPROSW and #PMPROSWSL.

Converter Connectors

Connectors that convert a 9-pin D-Shell connector to a RJ11 phone jack-style connector.

Table 48-52. Converter Connectors

Description	Catalog Number	Price U.S. \$
RS-232 DB9 (F) / RJ11 (M) converter [converts DB9 (M) to RJ11 (M)]. Ideal for converting PMPP 1700 cables for use with PMPS 1500	0820	
RS-232 RJ11 (F) / DB9 (M) converter [converts RJ11 (M) to DB9 (M)]. Ideal for converting PMPS 1500 cables for use with PMPP 1700	0821	

Mounting Collars and Plates

Mounting plates and collars can be used when replacing older PanelMate products with newer models with no or minimal cutout changes required.

Table 48-53. Adapter Plates (Similar Look to a Painted Steel Front Panel)

Description	Catalog Number	Price U.S. \$
Micro PanelMate (D820, D830, D840) to 2- or 4-line ELC Graphics Panel (ELC-GPxx) Keypad	APPM1ELCGP4	
6" PM 500, 1000 to 6" (HMI06xx) Touchscreen and Function Buttons	APPM1HMI6	
8" PM (11xxK, 17xxK, 75xxK-8) Keypad to 8" (11xxT, 17xxT, 75xxT-8, 76xxT-8x) Touchscreen	APPS8A	
8" PM (11xxK, 17xxK, 75xxK-8) Keypad to 8" (HMI08CE) Touchscreen	APPM1HMI8	
9" PM 2000/Compact (24xx/25xx) Keypad to 8" PM (11xxK, 17xxK, 75xxK-8) Keypad ②	1524TP	
9" PM 2000/Compact (24xx/25xx) Keypad to 8" PM (11xxT, 17xxT, 75xxT-8, 76xxT-8x) Touchscreen	1524TPTS	
9" PM 2000 (26xx/27xx) Keypad to 8" PM (11xxK, 17xxK, 75xxK-8) Keypad ②	1527TP	
9" PM 2000 (26xx/27xx) Keypad to 8" PM 11xxT, 17xxT, 75xxT-8, 76xxT-8 Touchscreen	1527TPTS	
9" PM 2000 (26xx/27xx) Touchscreen to 8" PM (11xxT, 17xxT, 75xxT-8, 76xxT-8x) Touchscreen ②	1527TS	
10" PM 3000 (39xxK, 75xxK-10) Keypad to 10" (HMI10CE) Touchscreen and Function Buttons	APPM2HMI10	
10" PM 3000 (39xxT, 75xxT-10, 76xxT-10x) Touchscreen to (HMI10CE) Touchscreen and Function Buttons	APPM1HMI10	
10" PM ePro (7585K-10) Keypad to 10" ePro PS (76xxT-10x) Touchscreen	APPS10A	
13" PM 5000 (54xx) Keypad-Split to 12" (76xxT-12x) Touchscreen	APPS12B	
14" PM 4000 (45xx), 13" 5000 (55xx/57xx) Keypad to 12" PM ePro PS 12" (7685T-12) Touchscreen	APPS12A	
14" PM 4000 (45xx), 13" 5000 (55xx/57xx) Keypad to 15" (7585DT-15) Remote Touchscreen Display	APFP15A	

② Cutting is required to make the cutout wider; drilling is required for new stud holes. For touchpanel units, see Table 48-54 if cutting and drilling is not an option.

Accessories

Table 48-54. Adapter Collars (Raises front of PanelMate 1.00-Inch (25.4 mm) from the Mounting Surface)

Description	Catalog Number	Price U.S. \$
PM 2000/Compact (24xx) Touchpanel to PM 11xxK, 17xxK, 75xxK-8 Touchpanel Collar. For Type 12 installations only.	1524TPCOLLAR	
PM 2000 (26xx/27xx) Touchpanel to PM 11xxK, 17xxK, 75xxK-8 Touchpanel Collar. For Type 12 installations only.	1527TPCOLLAR	

PanelMate Overlay Kits

The overlay kits are ideal for protecting your screens from dirt, grime and abrasion and are particularly desirable for PanelMate touchscreen models installed in dirty environments. These overlays can be ordered as clear or with an additional anti-glare feature. The overlays simply adhere to the front of the display and can be easily removed and replaced when required. Five overlays are included in each kit.

Table 48-55. Overlay Kits

Description	Catalog Number	Price U.S. \$
8.4" Anti-Glare Overlay Kit, 5 overlays/kit, for use with PanelMate 11xxT, 15xxT, 17xxT, 75xxT-8, 76xxT-8x, and HMI08CE	17AGT	
8.4" Clear Protective Overlay Kit, 5 overlays/kit, for use with PanelMate 11xxT, 15xxT, 17xxT, 75xxT-8, 76xxT-8x, and HMI08CE	17CPT	
10.4" Anti-Glare Overlay Kit, 5 overlays/kit, for use with PanelMate Power Pro 3000, 5000 (All 10.4" Models), 75xx-10 (All Models), 76xxT-10x, and HMI10CE	39AG	
10.4" Clear Protective Overlay Kit, 5 overlays/kit, for use with PanelMate Power Pro 3000, 5000 (All 10.4" Models), 75xx-10 (All Models), 76xxT-10x, and HMI10CE	39CP	
13.0" Anti-Glare Overlay Kit, 5 overlays/kit, for use with PanelMate Power Pro 5000 (All 13.0" Models)	55AG	
13.0" Clear Protective Overlay Kit, 5 overlays/kit, for use with PanelMate Power Pro 5000 (All 13.0" Models)	55CP	
12.1" Anti-Glare Overlay Kit, 5 overlays/kit for use with 12" PanelMate ePro PS 12" models (76xxT-12x) and 12" Stand-Alone Touchscreen Displays (7585DT-12)	AG-12	
15.0" Anti-Glare Overlay Kit, 5 overlays/kit for use with PanelMate ePro PS 15" models (76xxT-15x) and 15" Stand-Alone Touchscreen Displays (7585DT-15)	AG-15	
17.0" Anti-Glare Overlay Kit, 5 overlays/kit for use with 17" Stand-Alone Touchscreen Displays (7585DT-17)	AG-17	

PanelMate Pro LT 1100 Tags

The PanelMate Pro LT 1100 I/O Reference Point Expansion is an upgrade kit that includes a hardware key and download software. The upgrades are provided on the hardware key and are downloaded to a PanelMate Pro LT 1100 from a PC using the provided hardware key and software. The PanelMate Pro LT supports 64 I/O points as standard and can be upgraded to support a maximum of 512 I/O points (7 upgrades installed).

Table 48-56. PanelMate Pro LT Expansion ①

Description	Catalog Number	Price U.S. \$
I/O Reference Point Expansion (64 points per upgrade) 1 x 64 I/O point expansion 5 x 64 I/O point expansion 10 x 64 I/O point expansion 50 x 64 I/O point expansion	1100TAG1 1100TAG5 1100TAG10 1100TAG50	

① Discount Symbol **PM-2**.

PanelMate ePro PS Restore Kits

Each Restore Kit provides a simple way to reset the load of the PanelMate ePro PS internal CompactFlash® that holds the operating system to the factory-installed image. This kit is typically used as a field-recovery method for operating system problems, but it can also be used to upgrade the image load of installed units.

Each Restore Kit can be re-used to restore multiple PanelMate ePro PS units or to restore the same PS unit multiple times. The kit used for restoring the factory-installed image must match the model type of the unit being restored to maintain product integrity.

Installation requires a Microsoft-compatible USB keyboard and mouse and an Ethernet network connection.

Table 48-57. PanelMate ePro PS Restore Kits

Description	Catalog Number	Price U.S. \$
New RoHS Compliant Models ②		
Kit to restore PanelMate ePro PS, OD, and Classic units to the current factory image load	76MLPS	
Kit to restore PanelMate ePro PS EE units to the current factory image load	76MLEE	
Legacy Non-RoHS Compliant Models ②		
Kit to restore PanelMate ePro PS and PS OD Display units to the current factory image load	76MLPSD	
Kit to restore PanelMate ePro PS Blind Node units to the current factory image load	76MLPSB	
Kit to restore PanelMate ePro PS EE Display units to the current factory image load	76MLEED	
Kit to restore PanelMate ePro PS EE Blind Node units to the current factory image load	76MLEEB	
Kit to restore PanelMate ePro PS Classic Display units to the current factory image load	76MLPSCD	
Kit to restore PanelMate ePro PS Classic Blind Node units to the current factory image load	76MLPSCB	

② RoHS compliant units have a silver-colored galvanized steel back cover. Non-RoHS compliant units have a gold-colored plated steel back cover.

Discount Symbol **PM-1**

Table 48-58. PanelMate ePro (75xx Series) Spare Parts

Description	Catalog Number	Price U.S. \$
7.7" Color DSTN Display Assembly for 7575T-8 Series	63-00678	
8.4" Color TFT Display Assembly for 7585K-8 and 7585T-8 Series	63-00544	
10.4" Color TFT Display Assembly for 7585K-10 and 7585T-10 Series	63-00778	
Keypad with Window for 7585K-8 Series	63-00796	
Touchscreen for 7575T-8 Series (gaskets 32-01682 and 32-02437 required)	63-00837	
Gasket for Touchscreen (between touchscreen and front panel) for 7575T-8 Series	32-01682	
Gasket for Touchscreen (between touchscreen and display) for 7575T-8 Series	32-02437	
Touchscreen for 7585T-8 Series (gaskets 32-01682 and 32-02208 required)	63-00832	
Gasket for Touchscreen (between touchscreen and front panel) for 7585T-8 Series	32-01682	
Gasket for Touchscreen (between touchscreen and display) for 7585T-8 Series	32-02208	
Keypad for 7585K-10 Series (does not include window)	63-00805	
Plexi-Glass Window for 7585K-10 Series	32-02151	
Touchscreen for 7585T-10 Series	63-00585	
Gasket for Touchscreen for 7585T-10 Series (between touchscreen and display)	32-02145	
Front Panel Assembly for 7585K-8 Series	91-01985	
Front Panel Assembly for 7575T-8 and 7585T-8 Series	91-01494	
Front Panel for 7585T-10 Series (gaskets 32-02144 and 32-02145 required)	32-02444	
Gasket for Front Panel for 7585T-10 Series	32-02144	
Gasket for Touchscreen for 7585T-10 Series	32-02145	
Backlight Kit for 7585K-8 and 7585T-8 Series	87-02455	
Backlight Kit for 7585K-10 and 7585T-10 Series	87-02379	
Ship Kit for 7585K-8 Series	86-00086	
Ship Kit for 7575T-8 and 7585T-8 Series	86-00083	
Ship Kit for 7585T-10 Series	86-00085	
ISA 1 Port PanelMate PC Adapter	D712-DHP-ISA	

Table 48-59. PanelMate Power Series 2000 Spare Parts

Description	Catalog Number	Price U.S. \$
Display Assembly for 24xx	91-01430	
Display Assembly for 26xx	91-01425	
PanelMate Power Series Upgrade Kit (adds high capacity, dynamic graphics, advanced trending and Modbus enabler)	PMUPGRADE	
Membrane Keypad (4-position) for 24xx, 26xx, 27xx	63-00395	

Table 48-60. PanelMate Power Series 3000 Spare Parts

Description	Catalog Number	Price U.S. \$
Keypad with Window for 39xx	63-00743	
Touchscreen for 39xx	63-00285	
PanelMate Power Series Upgrade Kit (adds high capacity, dynamic graphics, advanced trending and Modbus enabler)	PMUPGRADE	

Legacy Products Spare Parts

Table 48-61. PanelMate Power Series 4000 Spare Parts

Description	Catalog Number	Price U.S. \$
Display Assembly for 42xx, 45xx	91-01538	
Membrane Keypad (5-position) for 42xx	63-00376	
Membrane Keypad (15-position) for 42xx	63-00375	
Cable for Remote Keypad	90-00594	
Membrane Keypad (5-position) for 45xx	63-00391	
PanelMate Power Series Upgrade Kit (adds high capacity, dynamic graphics, advanced trending and Modbus enabler)	PMUPGRADE	
Touchscreen for 45xx	63-00773	

Table 48-62. PanelMate Power Series 5000 Spare Parts

Description	Catalog Number	Price U.S. \$
Membrane Keypad (15-position) for 52xx	63-00375	
Cable and Remote Keypad for 52xx	90-00594	
Touchscreen for 55xx	63-00773	
Touchscreen Cable for 55xx	90-00715	
PanelMate Power Series Upgrade Kit (adds high capacity, dynamic graphics, advanced trending and Modbus enabler)	PMUPGRADE	
Backlight Kit for 52xx, 55xx	87-01783	

Table 48-63. PanelMate Power Series 1000 Spare Parts

Description	Catalog Number	Price U.S. \$
Front Panel, Keypad Assembly, Painted Steel for 1218	FRPNL-1218	
Front Panel, Keypad Assembly, Stainless Steel for 218S	①	
Backlight Kit for 1218, 218S	87-02143	

① Contact factory.